

The A' Experiment (**APEX**)
Searching for New Gauge Bosons in the A'
Experiment at Jefferson Laboratory

March 2014 (Short) Status Report
see Feb 28 2014 meeting material for details

Philip Schuster (Perimeter Institute)

Rouven Essig (Stony Brook)

Natalia Toro (Perimeter Institute)

Bogdan Wojtsekhowski (JLab)

on behalf of APEX

Hall A Projected Experiment Schedule as of 12/2013

	Spring	Fall	Spring	Fall	Spring	Fall	Spring
2014	Hall Checkout	DVCS - I / G_M^p					
2015			DVCS - I / G_M^p	$^3\text{H}/^3\text{He}$			
2016					(A_1^n) (APEX) (PREX) (CREX)	(A_1^n) (APEX) (PREX) (CREX)	
2017							(as above, <u>plus</u> DVCS-II and SBS)

Experiments in parentheses are anticipated to be ready and appropriate for the indicated time slot, and so represent potential options - in no particular order.

SBS



MOLLER,
SOLID...?....



Jefferson Lab

Status Report & Readiness

- SciFi detector for optics calibration
 - Both detectors, optical cables, and PMT assemblies are constructed. One detector is tested (without PMT).
- APEX extended target
 - target built for test run is at JLab
- Septum
 - Design is finalized. Drawings are produced. Magnet has been ordered. Delivery is expected in June.
- HRS detector maintenance is proceeding
 - Detectors are installed, cosmics tests underway, beam tests in March 2014

Magnetic Spectrometer Optics

Measuring Contributions to the Mass Resolution
(dominant: **angular resolution** + mult. scatter)

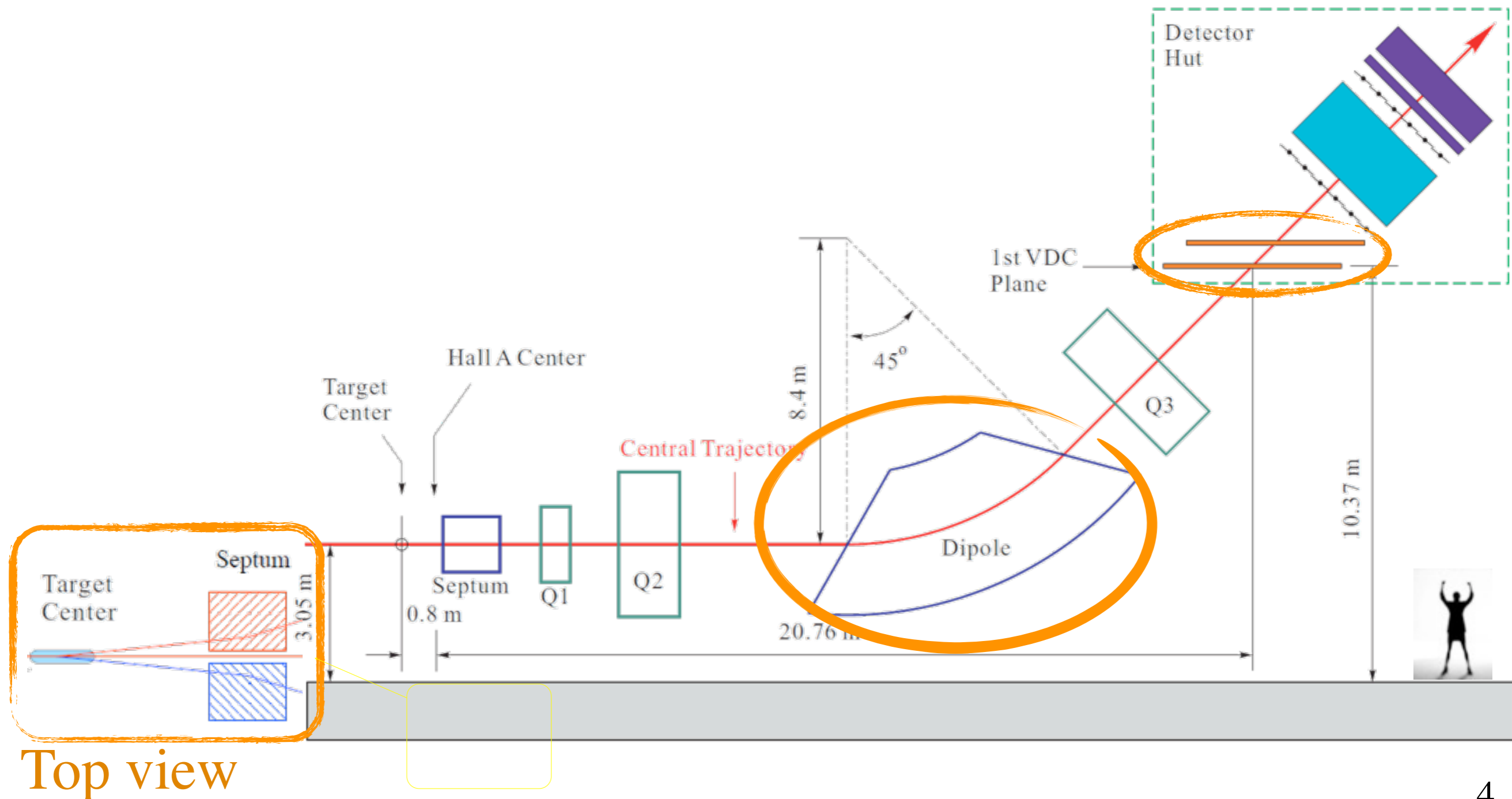

Test Run Optics Calibration

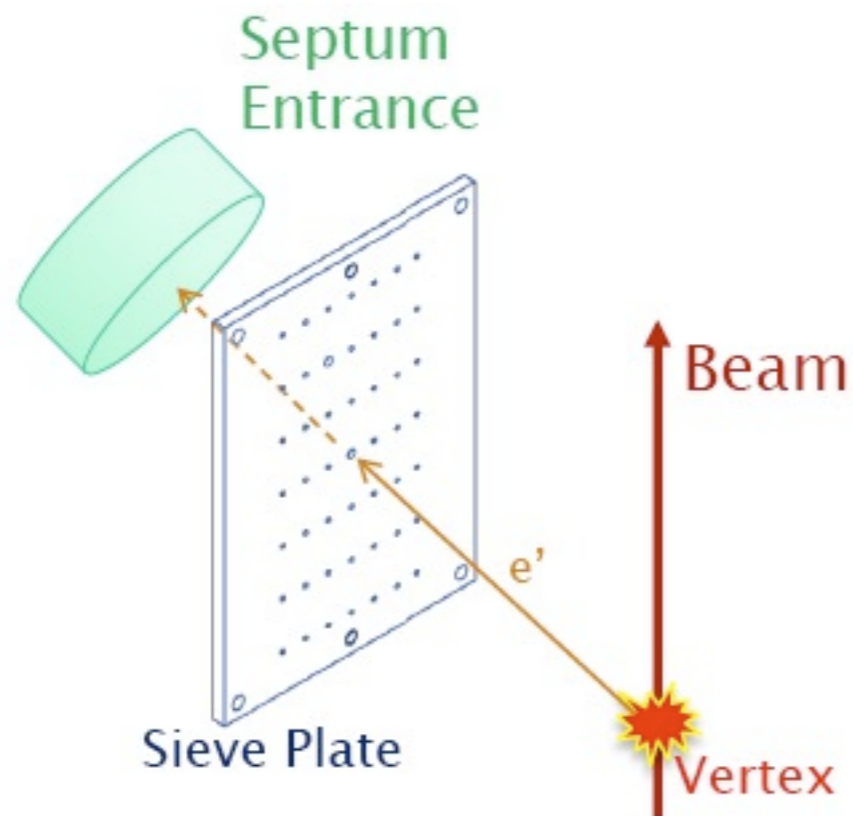

Removable sieve plate is inserted upstream of septum.

Use surveyed locations of sieve holes to calibrate magnetic optics.

Use reconstructed hole sizes to measure resolution.

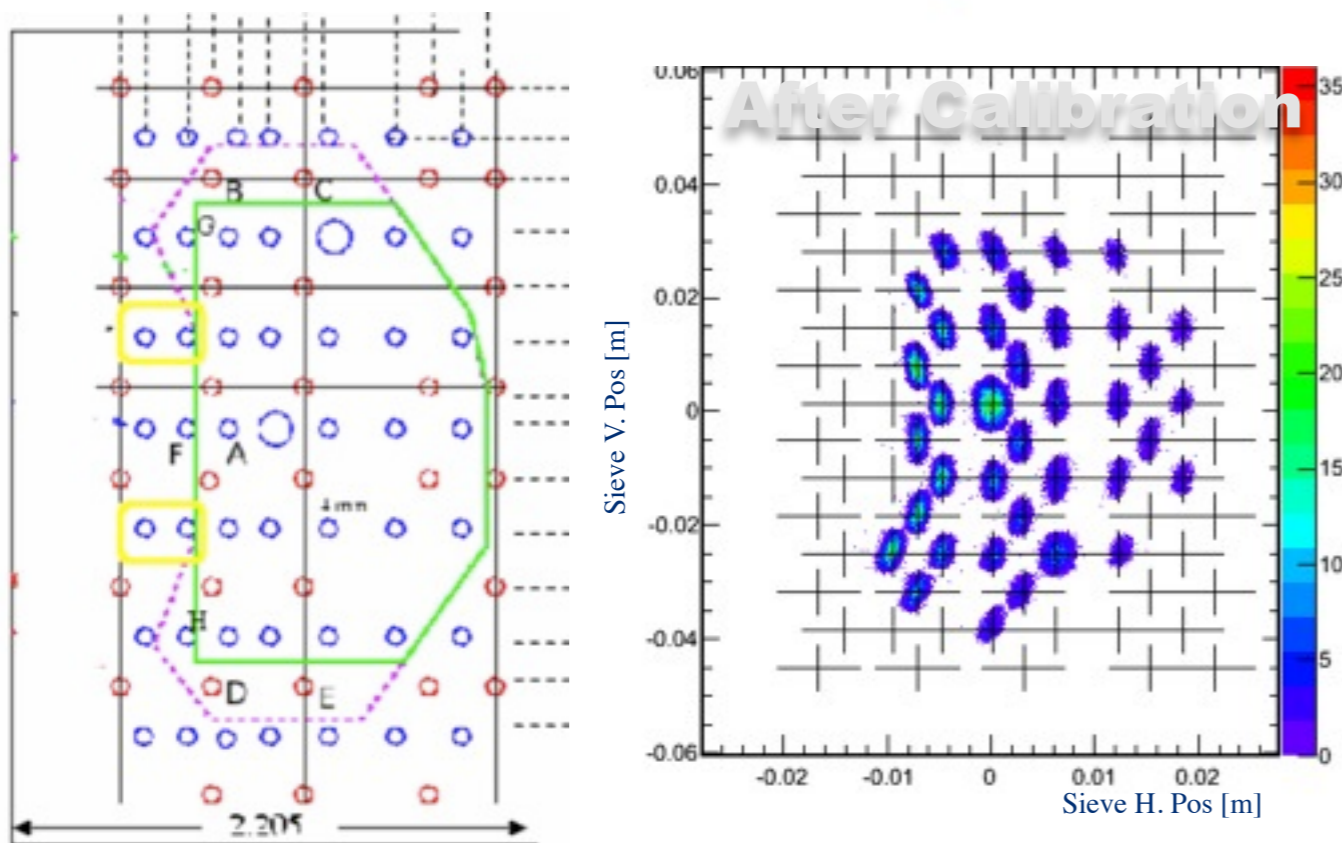

...this method only works for negative polarity, and requires running at different beam energy.

**Mass resolution ≈ 1 MeV
 $\sim 0.5\%$**

HRS optics

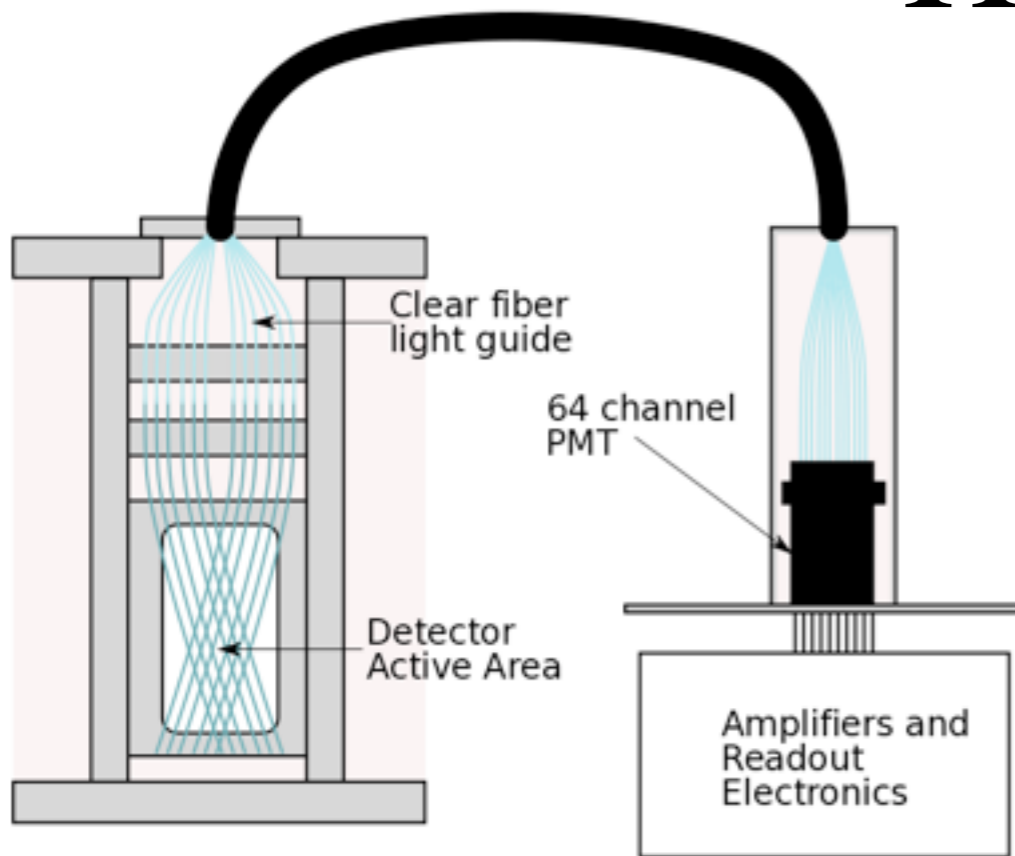

“Active sieve slit”: tagging by a Sci Fiber detector

- 1 mm fibers with 1/16” pitch
(equivalent to 1024 sieve holes)
- Projected rate: 1-3 MHz per fiber
- Off-line time window < 5 ns
- **Help needed to complete project**

Allows optics calibration **at production beam energy & for both polarities**

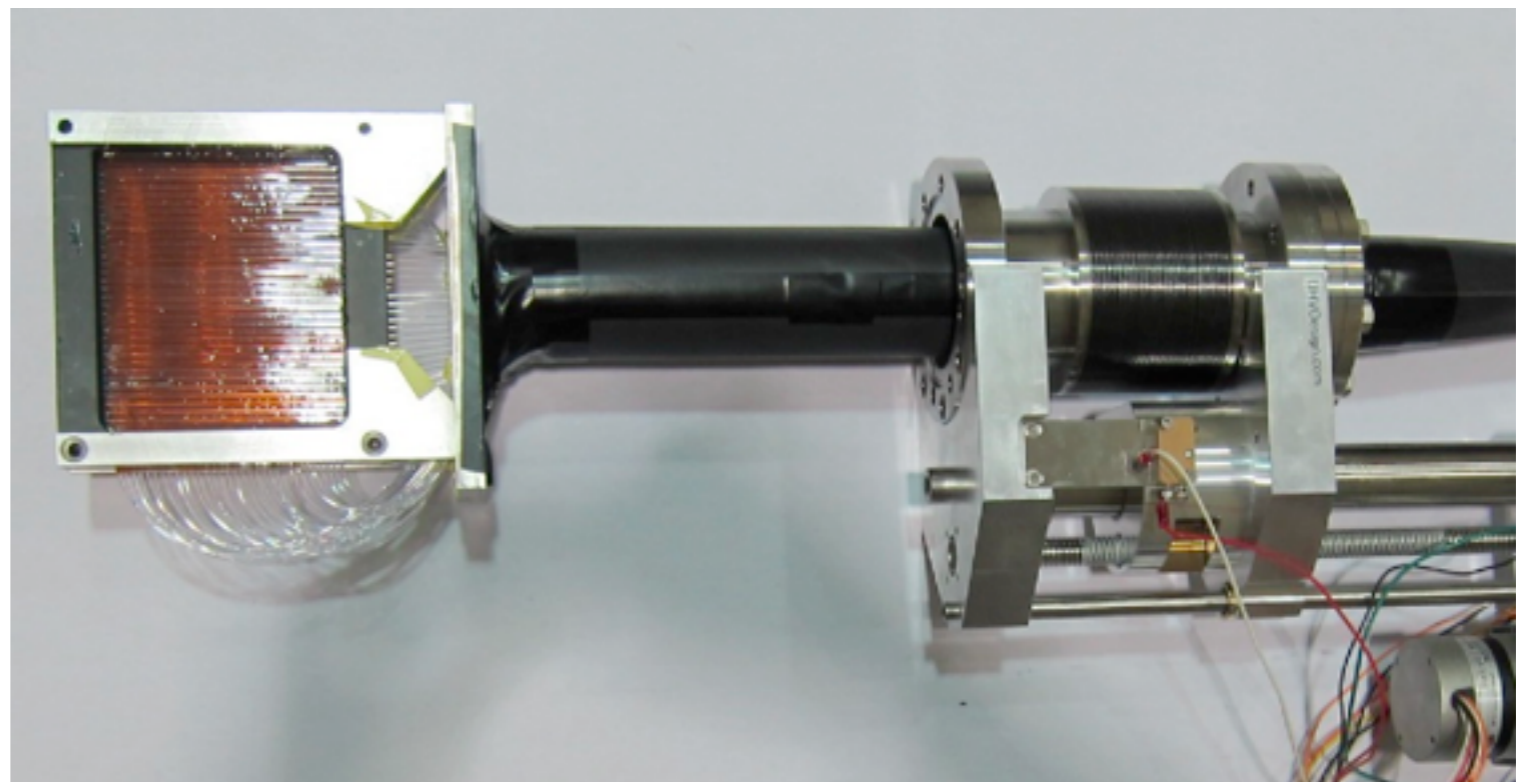
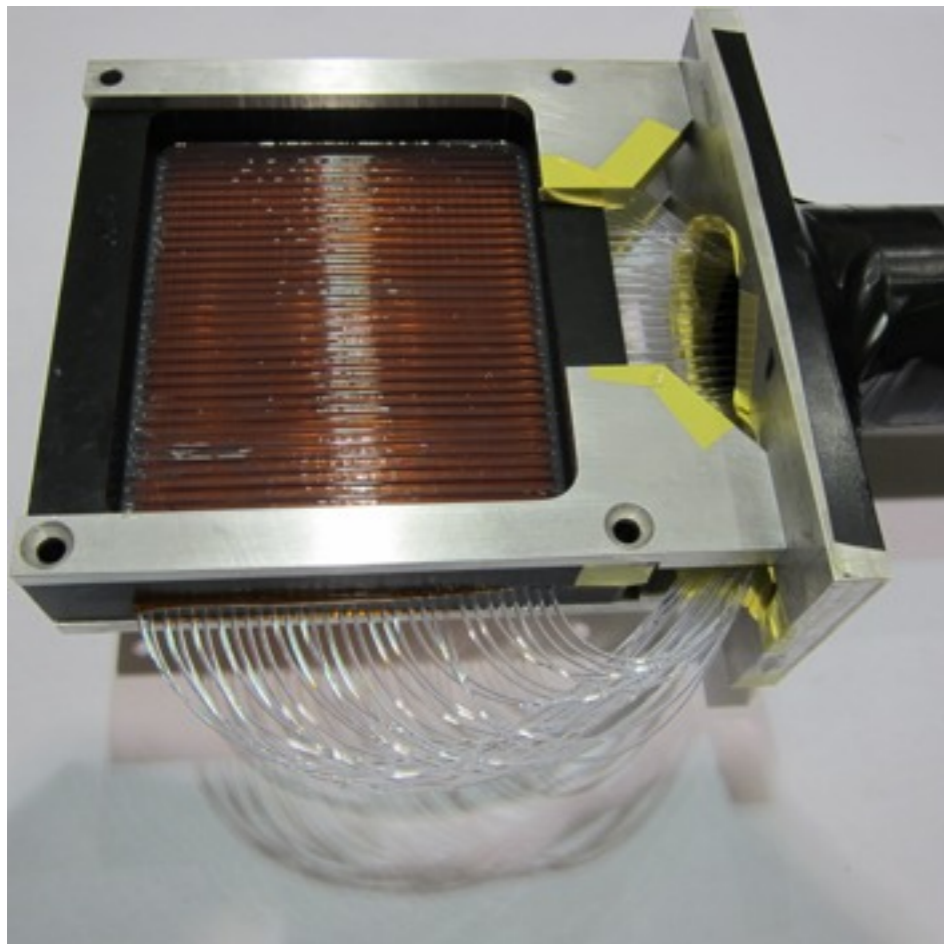

SciFi & Optics To-Do List:

- SciFi Commissioning: DAQ and Readout
- Need to develop expertise in SciFi use to prepare for optics calibration
- Help would be immediately useful!

Target Design: Minimizing Multiple Scattering

Target designed and built by SLAC APEX group for the test run (but not installed), currently at JLab.

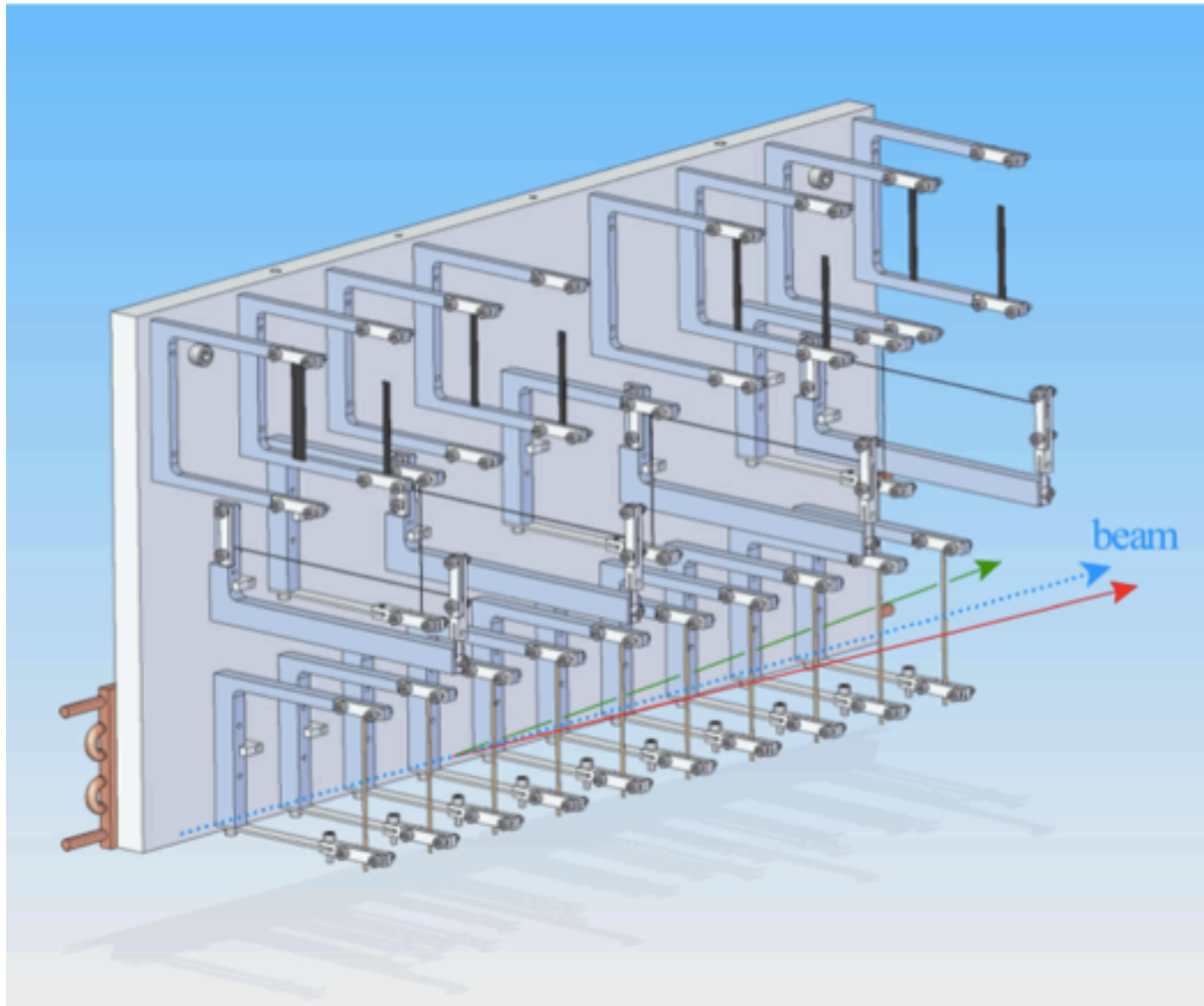

Target Design: Minimizing Multiple Scattering

Target designed and built by SLAC APEX group for the test run (but not installed), currently at JLab.

Goals:

- $\sigma(\theta)_{\text{mult scat}} \leq 0.5 \text{ mrad}$
 \Rightarrow typical e^+e^- pair must only go through 0.3% X_0 (2-pass)
- Target thickness 0.7–8% X_0 (depending on E_{beam})

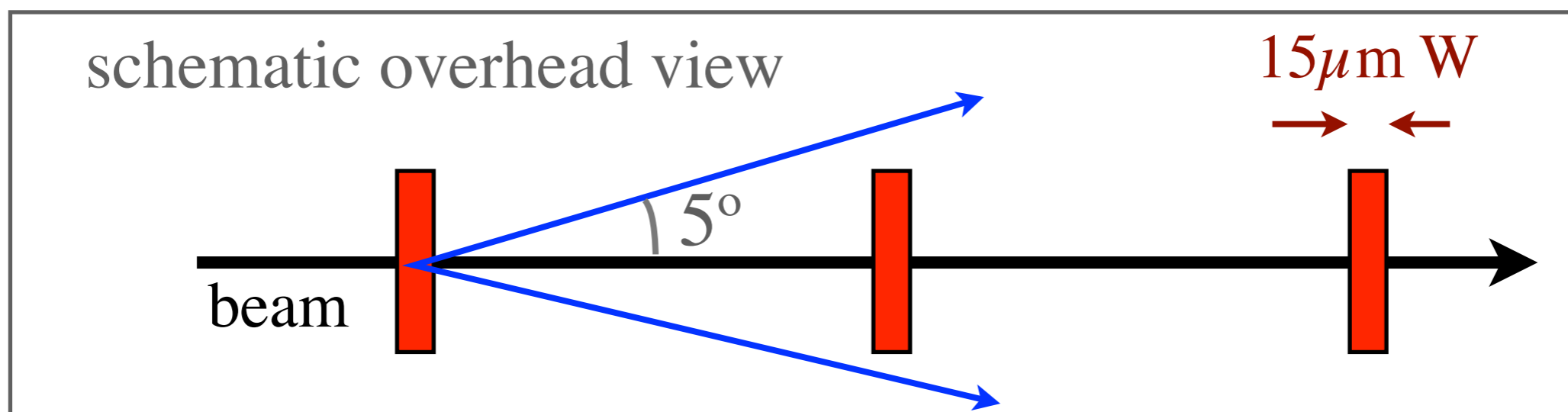

- High-Z target (reduce π yield for given QED rates)
- Stable under currents up to $\sim 100 \mu\text{A}$

long target \Rightarrow wider single-run mass coverage

Target To-Do List:

- Develop plan of target operation
- Additional target holders required.
- Analysis of heat load and cooling for 1, 3, & 4 pass settings needed, and repeat 2 pass analysis

New HRS Septum Magnet

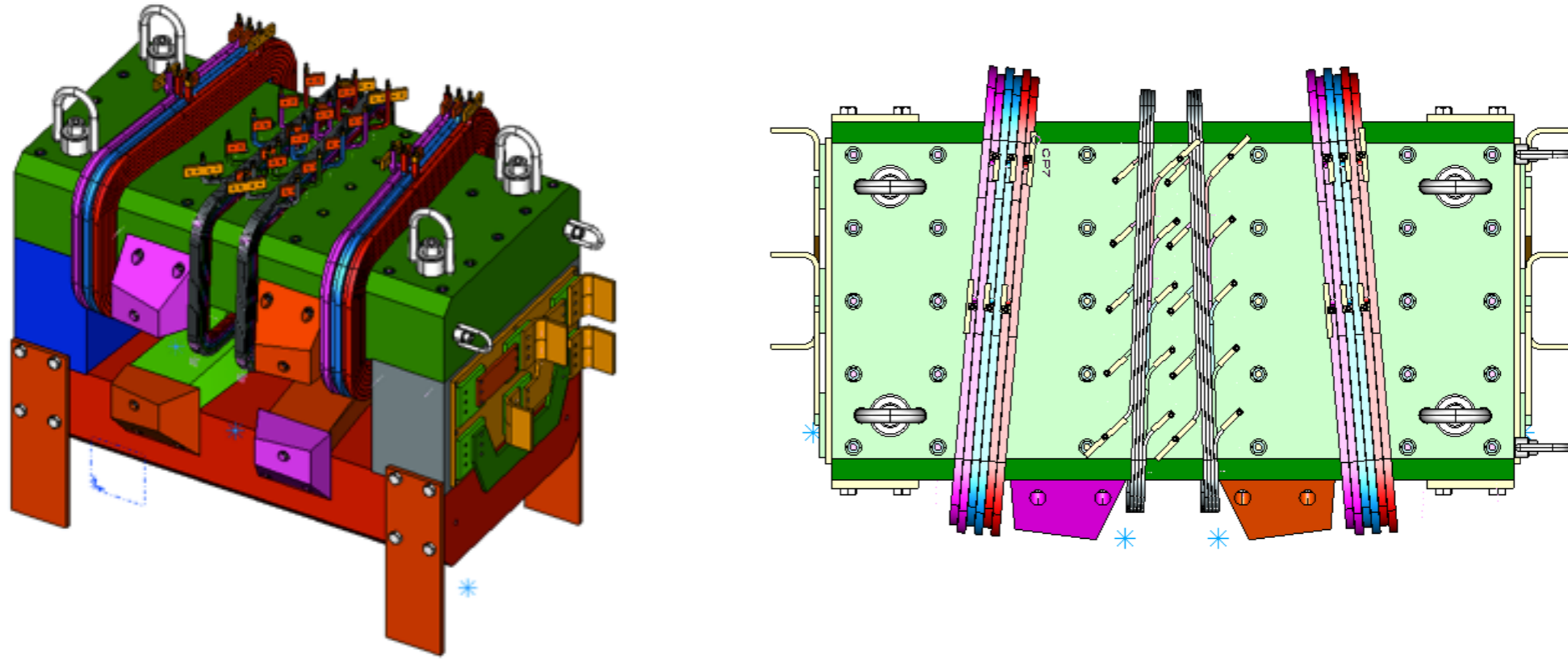

- Designed for parallel field capability
(minimize fringe field near beamline)
- Optimized for full angular acceptance
- High density coils used to enable full energy range required (up to 2.2 GeV momentum electron and positron)

New HRS Septum Magnet

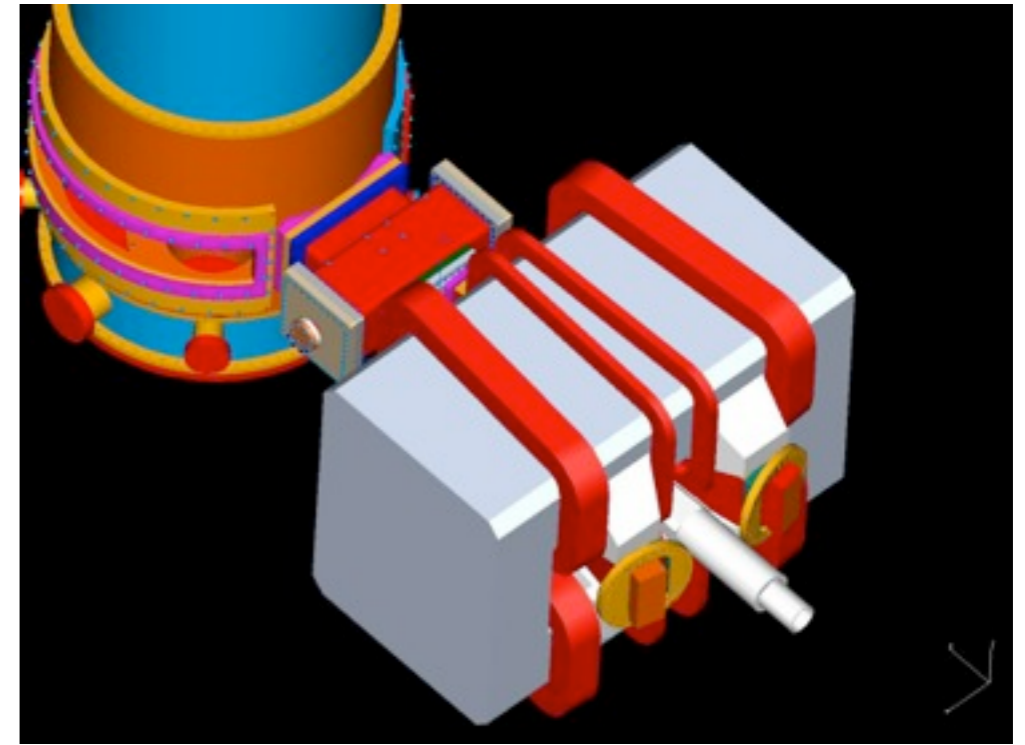
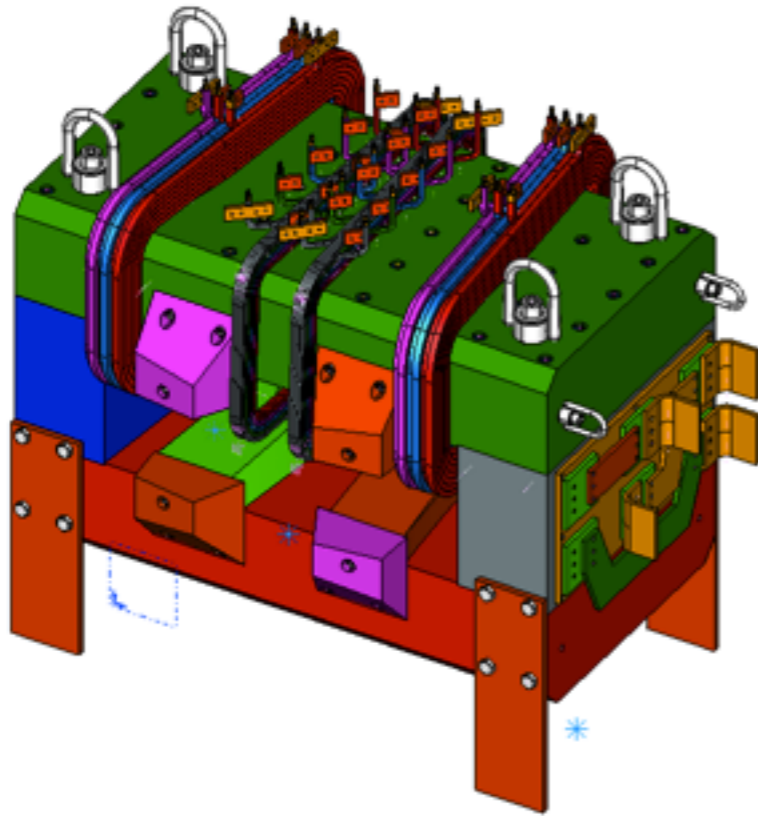

- Buckley Systems constructing the magnet system (expected completion by end of summer 2014)
- New extension box and vacuum connections for beamline and to the spectrometers needed (additional 10K design costs need to be covered by collaboration, 3K already promised)
- Need to develop expertise in acceptance calculations with the new septum magnet (John LeRose did this before).

Critical Projects

- SciFi Commissioning
- Target System Preparations
- HRS Septum Magnet, and associated beamline
- Preparation of Software -- VDC & PID (more on this at collaboration meeting)

Summary

APEX has demonstrated feasibility and power of spectrometer searches for hidden-sector photons

Strong physics impact already from test run
(highly cited Hall A result)

APEX can explore important range of mass and coupling *very efficiently*

Opportunity for immediate science impact – even with commissioning-quality beam.

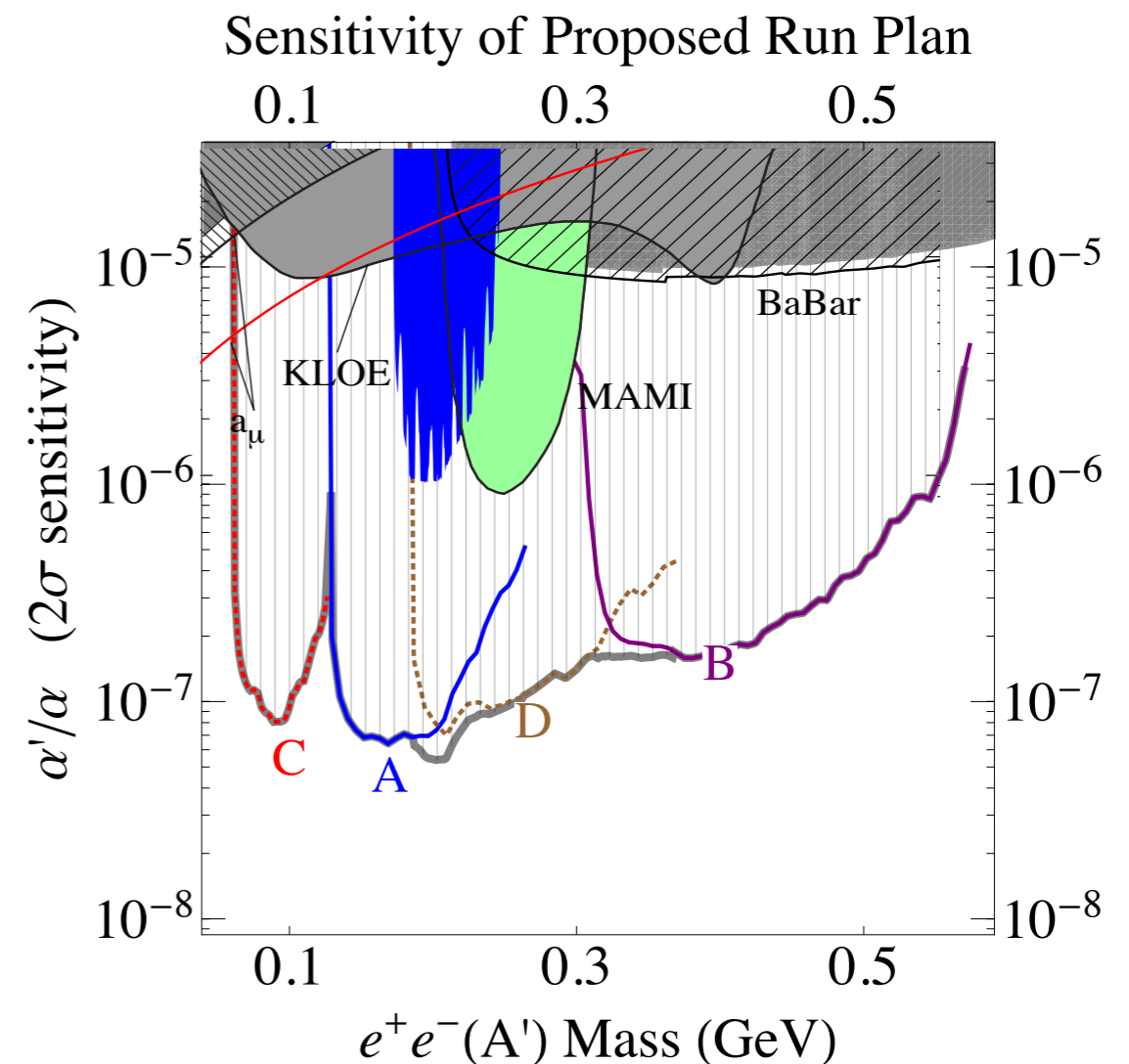

Backup

Expenses and Funding

Assumptions were made:

- a) The SBS power supply is installed, operational with the current bus to the SBS location
- b) Shielding plan for the HRS power electronics is accepted by RadCon (needs a review)
- c) Installation manpower is provided by Hall A
- d) Hall A scientific manpower is not counted

Beam line hardware

Item	Design and engineering cost	Construction cost	Status, 3/1/2014 Comments
Septa	\$16k (NCCU), complete	\$79k, Canadian NSERC Discovery Accelerator Award, P. Schuster, Waterloo & Perimeter Institute	ordered, \$134k, delivery in July 2014
		\$25k, Alfred P. Sloan Foundation, R. Essig, Stony Brook	
		\$15k, Dep. head's Fund, G. B. Franklin, Carnegie Mellon	
		\$15k, NSF, CSULA, K. Aniol	
Vacuum connections	\$3k, (HU+RU) \$5k, Collaboration 1 m-w design, Hall A	estimated cost \$30k	design is under way
Corrector magnets	\$2k, Collaboration 2.5 m-d design, Hall A	estimated cost \$5.5	ready for design
Extended target	SLAC, 2010, complete	SLAC, \$5k (2010)	requires 3 m-m postdoc, Collaboration
Sieve slits (optics)		existing pair	
Beam line corrector		existing magnet	
Septa magnet infrastructure: a. support platform b. water distribution c. current bus	Hall A designers: a) 1 m-m design b) catalog items c) 1 m-m design	Hall A, estimated \$5k Hall A, estimated \$5k Hall A, estimated \$10k	

Expenses and Funding

APEX detectors

HRS(s) detector packages	Hall A, 2013-2014	Part of HRS(s) preparation	ready by March 2014
SciFi - optics detectors	Hall A, 2012 complete	Hall A OPS, \$25k (2012), complete	requires 3 m-m postdoc, Collaboration

Hall A preparation

Radiation shield of the HRS power electronics supply	1 m-w design	Hall A, estimated \$3.5k	Reuse of existing (GEn) lead/steel shield
Beam line alignment	JLab geod. survey team	Hall A, estimated \$10k	
Installation		Hall A technical team	3 months

Summary	2.6 m-m Hall A designer \$7k, Collaboration	\$69k, primarily Hall A OPS	
----------------	--	-----------------------------	--

Expenses and Funding

New grant applications submitted (mainly to fund scientific manpower)

Agency	Title & Submitter	Amount
DOE (HEP) & NSF (submitted 9/13 & 10/13)	"The A' Experiment (APEX): Search for a New Vector Boson A' Decaying to e ⁺ e ⁻ ", R. Essig, Stony Brook	\$422,847 request included 1 postdoc for 3 years, 1 month summer salary, travel, equipment (\$10k corrector magnet, \$15k vacuum chamber, \$35k septum magnet)

Approved grants (mainly to fund scientific manpower)

Agency	Title & Submitter	Amount
DOE (NP)	"Experimental Medium Energy Physics" G. B. Franklin, Carnegie Mellon	\$2,936,000 Includes 3 years of support for Carnegie Mellon's activities in Hall A and Hall D. Expect to contribute, 1 graduate student, 50% of a post-doc, 0.25 FTE faculty to the APEX experiment over the 3-year grant period.

Good time for this support to begin is Summer 2014