



Target Spin Flip Control and DAQ System Design

Jin Huang

Ph.D. Candidate

Massachusetts Institute of Technology

Description & Goals

- ▶ The goal of this project is building a software & hardware mixing system, which
 - Control the target spin flip consequence
 - Record current spin state
 - Output spin related information into data stream
 - Interface with human and EPR calibration
- ▶ Reliability is the key
 - One fail flip = loose of polarization measurement precession
 - Check, Double Check, Triple check

Target Spin Flip (Core Devices)

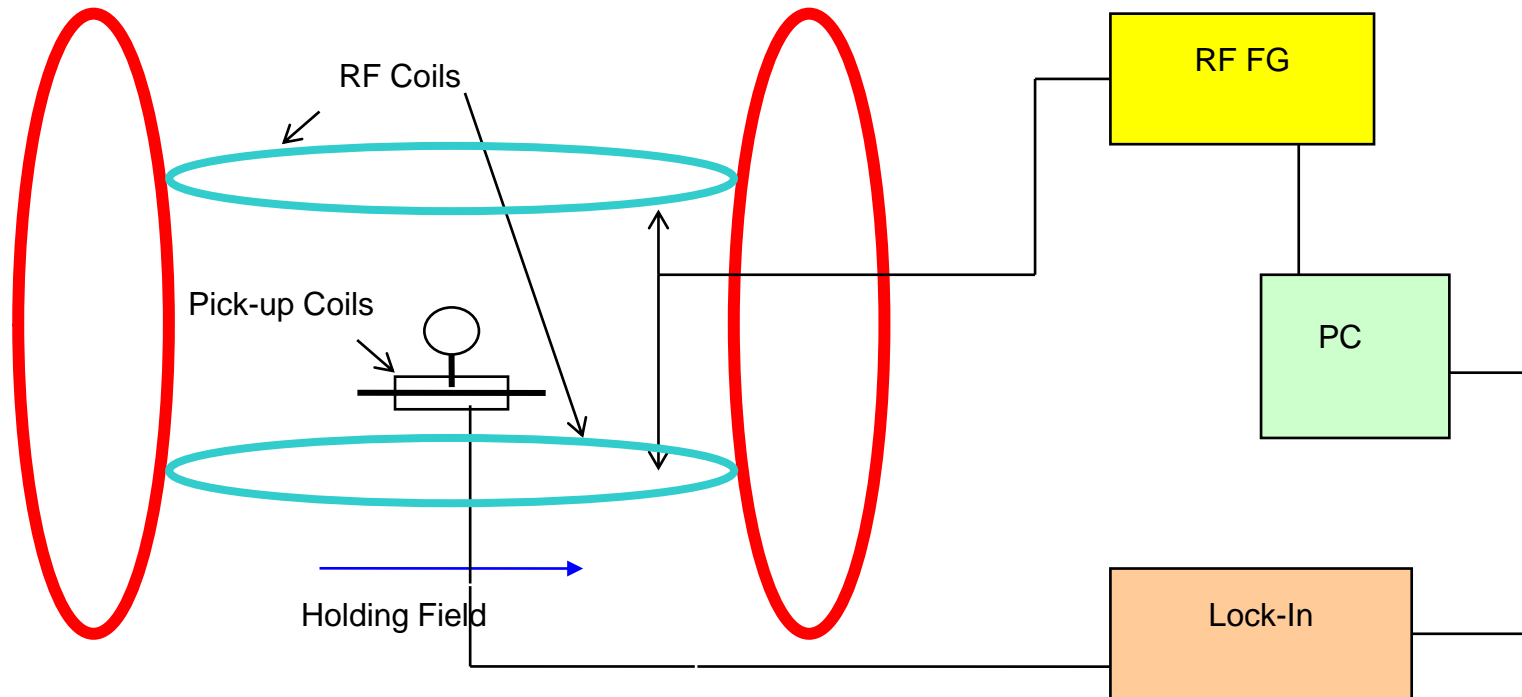

Stolen from X. Zhan, B. Moffit
http://www.jlab.org/~moffit/meetings/BigFamily/Target_spin_update.doc

Target Spin Flip (Time Line)

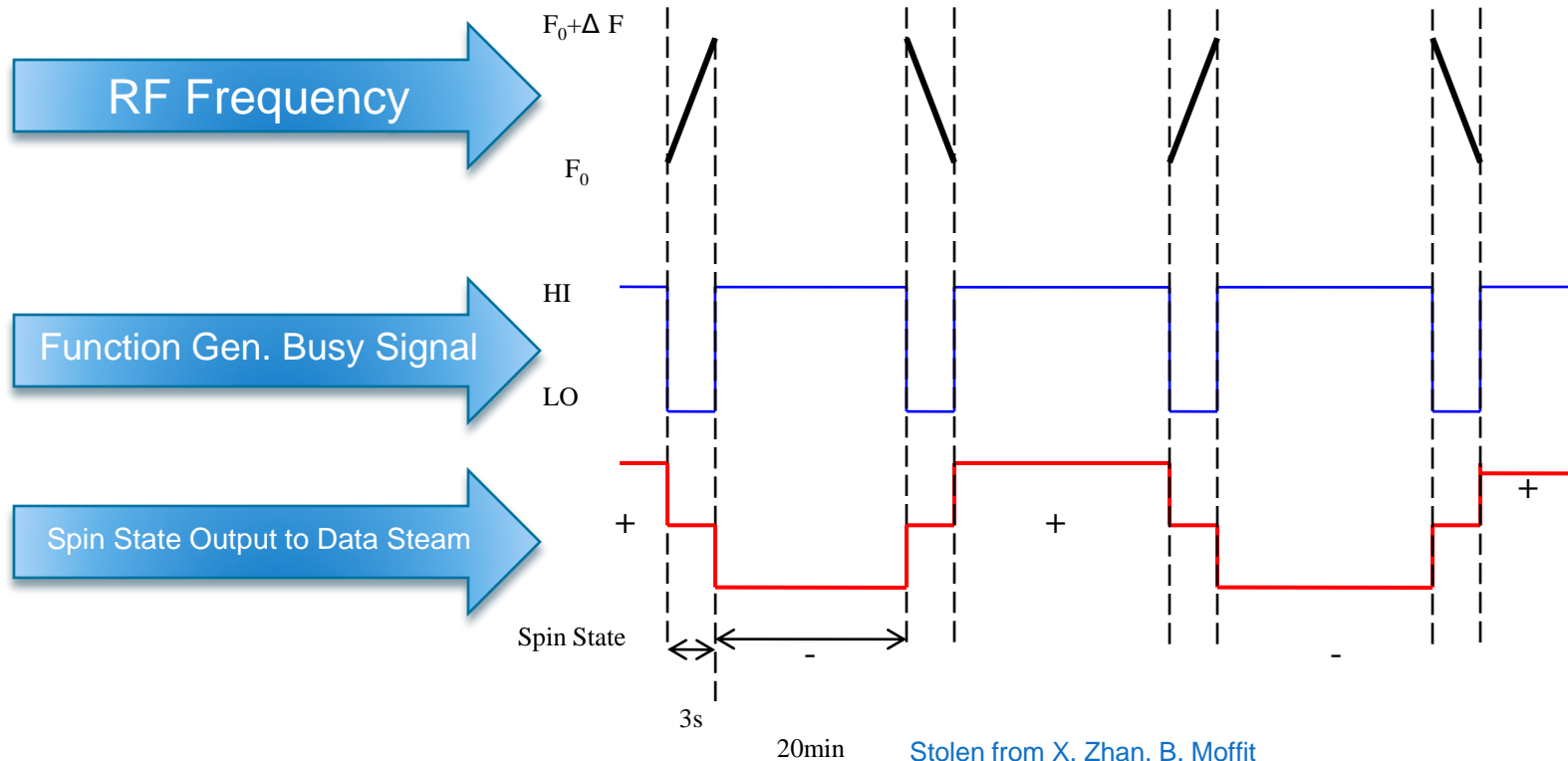

Stolen from X. Zhan, B. Moffit
http://www.jlab.org/~moffit/meetings/BigFamily/Target_spin_update.doc

Function Diagram

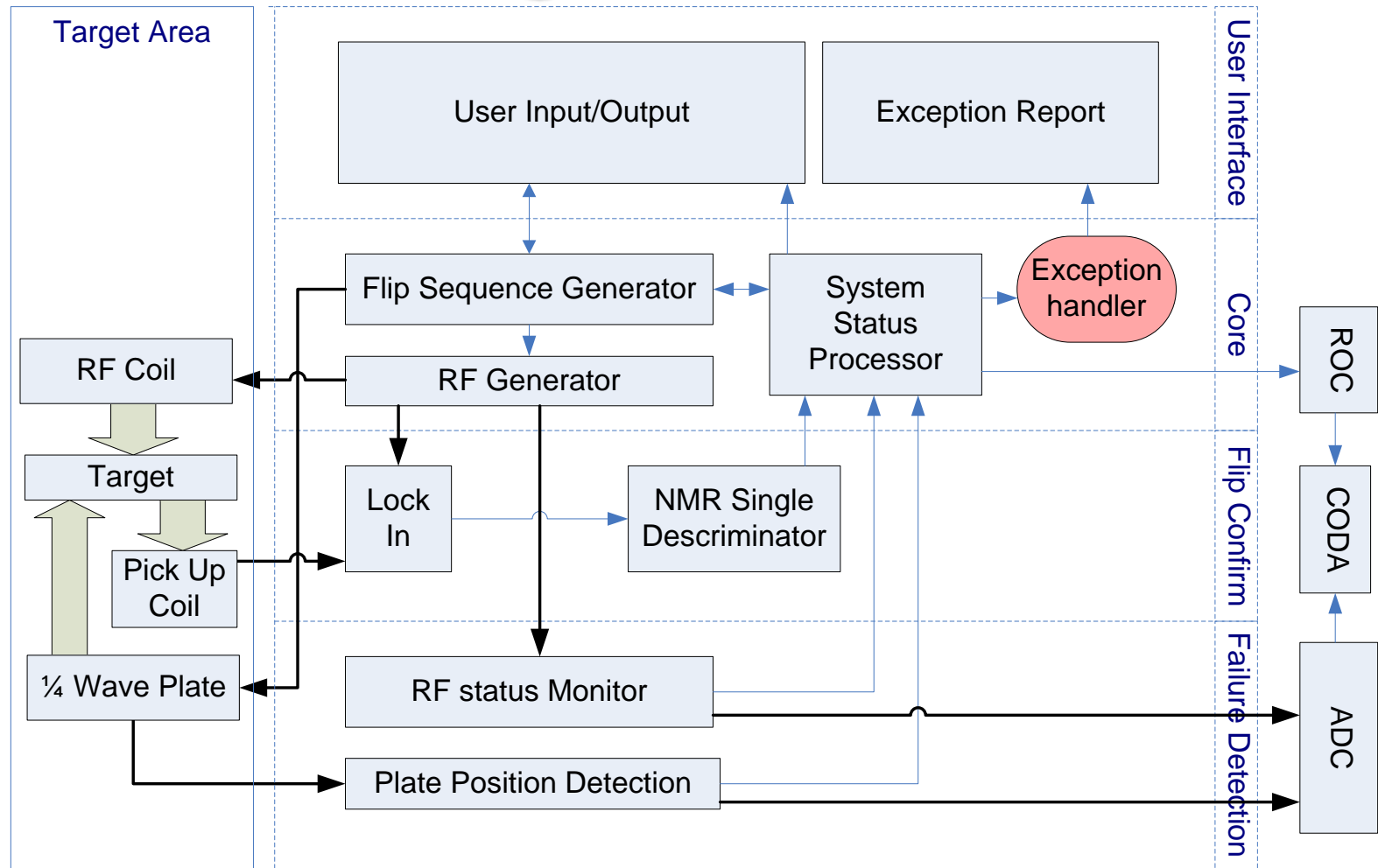

Physical Layout

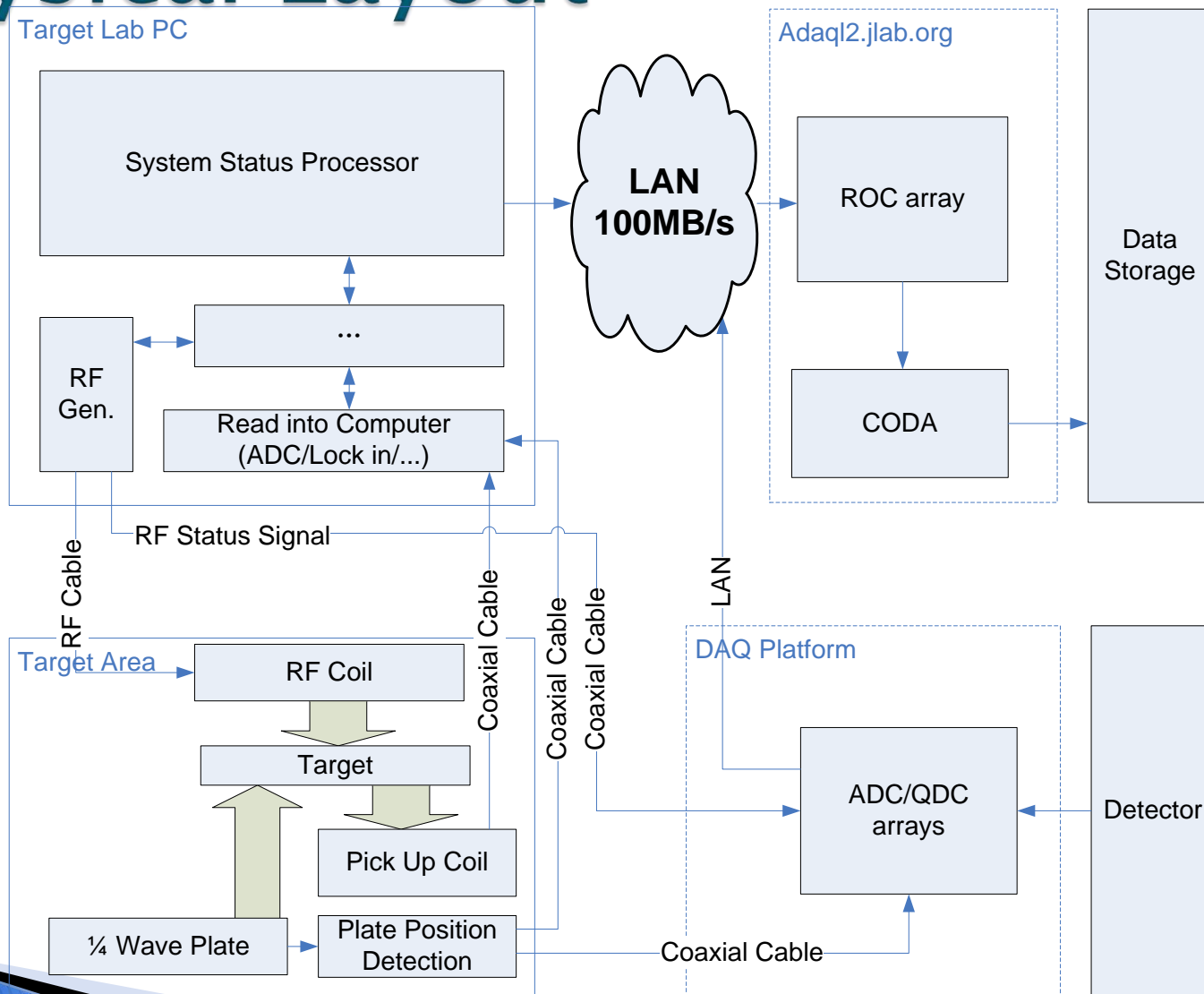

Logical Diagram (Event Driving Model)

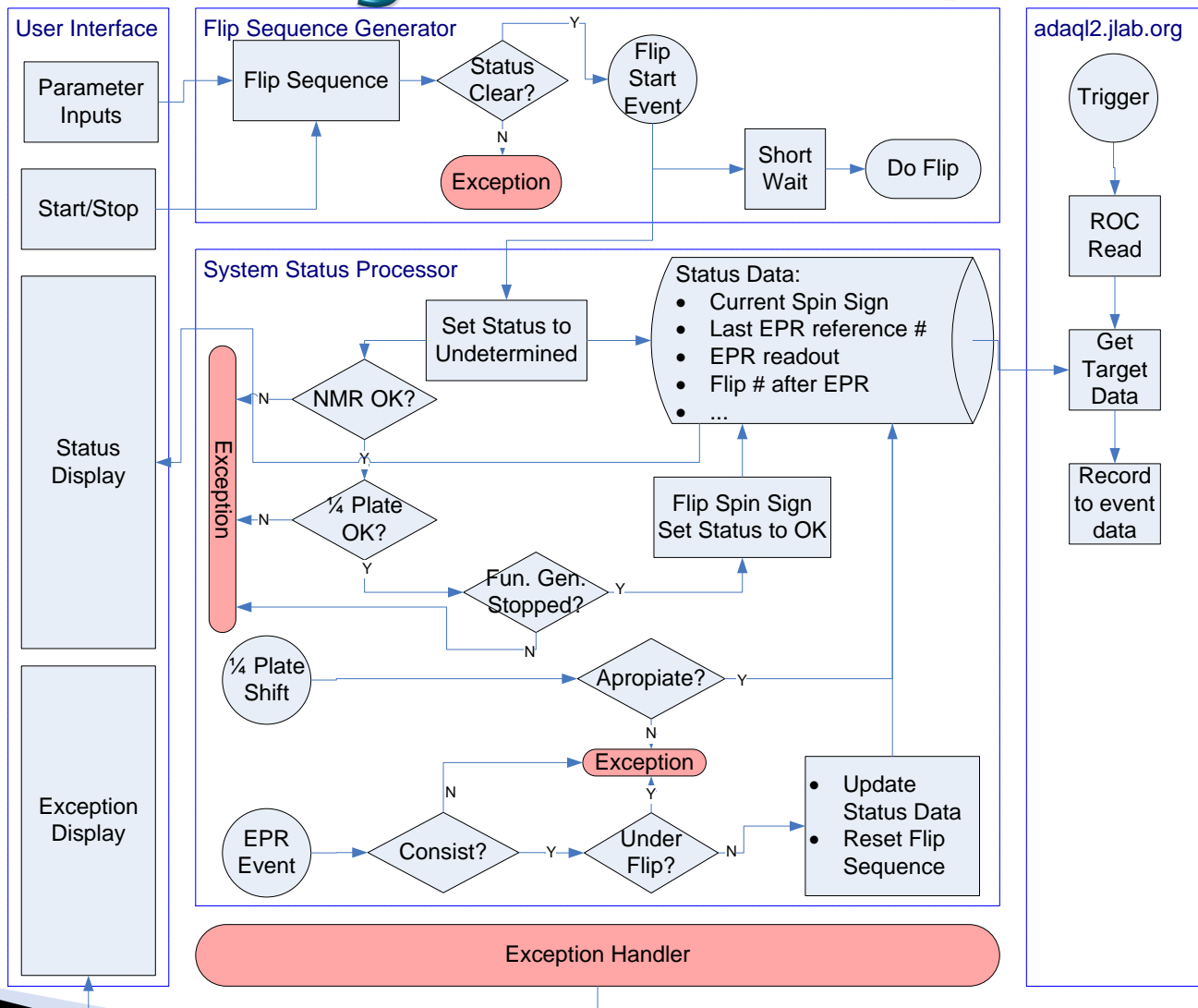

Experiment Time Line

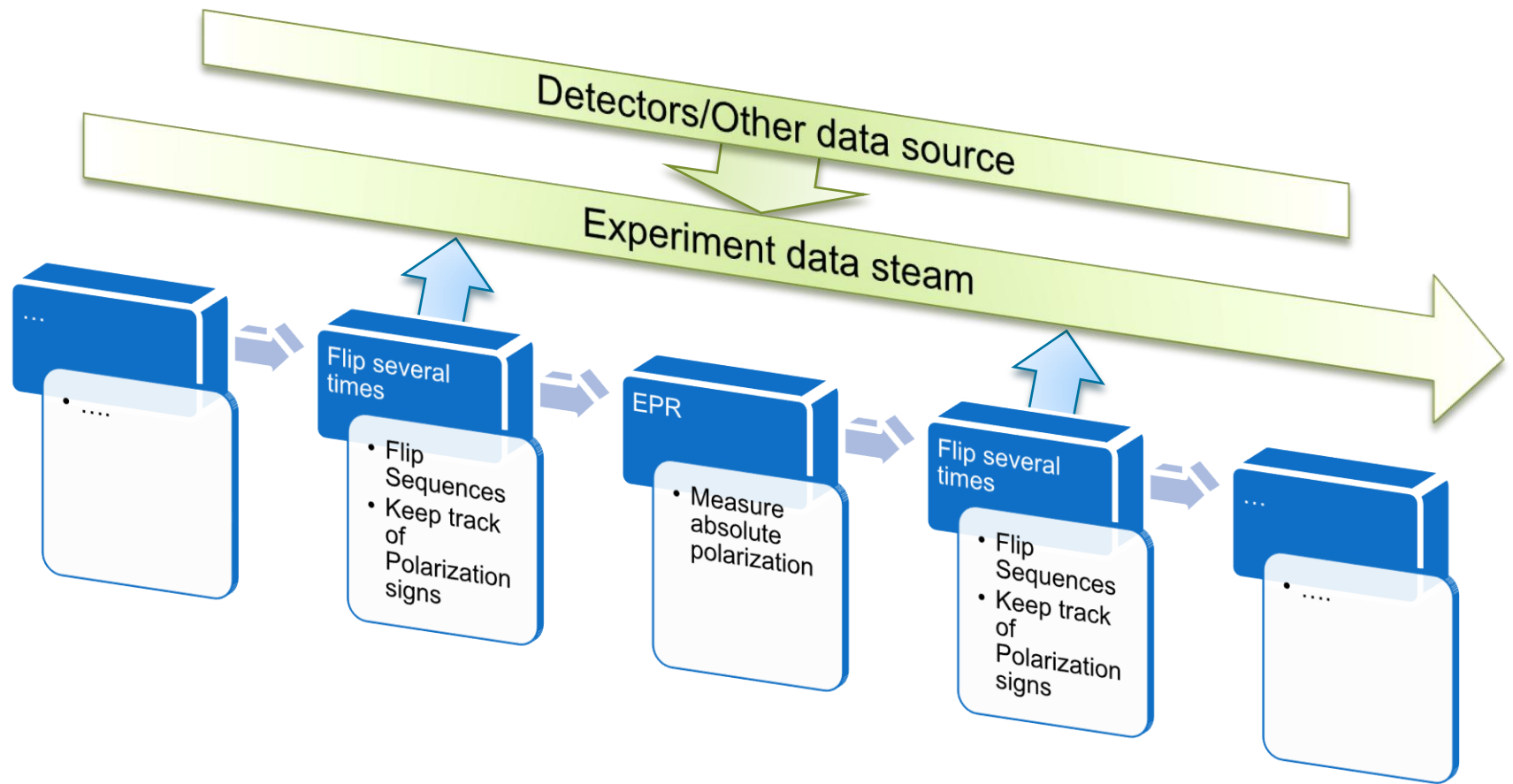

Exception Handling

What to do after failed one flip ...

- ▶ Stop spin flip
- ▶ Send indeterminate signal to DAQ
- ▶ Log the failed sequence ID
- ▶ Warn Shift worker

Future Feature may include:

- ▶ Auto Start EPR



Analyzing Preview

What would the target spin data appear in final analysis?

- ▶ In analyzer: THaTarget. GetTargetPolarization()
- ▶ In Root File: T->TarSpin
- ▶ ...

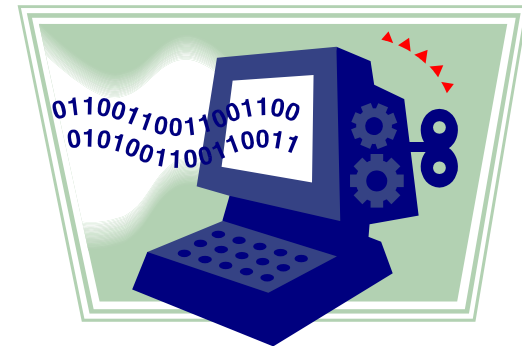

Already Exists

- ▶ Code Do Simple Spin Flip
- ▶ Target Instrument Supporting Spin Flip
- ▶ NMR Signal Readout

To Be Developed

- ▶ Main Control Frame
- ▶ NMR Signal Discriminator
- ▶ $\frac{1}{4}$ Wave Plate Position Readout
- ▶ Send Data to DAQ

Possible Future Upgrades

- ▶ A more functional Exception Handler