

1 Summaries of Hardware Development Activities

1.1 E06-002

A Room Temperature Septum Magnet for PREX

John J. LeRose, Paul Brindza, and Bob Michaels

1.1.1 Room Temperature Septum Magnet

A new room temperature septum magnet has been designed and is being built for the PREX, E06-002, experiment. This new magnet, while being limited in its maximum central momentum, will make it possible to use the HRS's at central angles as small as 5° with uncompromised momentum and angular resolution and significantly higher luminosity than possible with the present superconducting septa. In fact, this magnet will not be a limiting factor in determining the maximum achievable luminosity. Acceptance, which will depend on the details of any particular experimental setup, will remain about the same as with the superconducting septa.

The general layout is illustrated in Figure 1. Notice that this magnet features a monolithic iron yoke with two separate coil and pole packages. Different central angles are attained by simultaneously moving the target position and rotating both HRS's around the pivot while keeping the septum fixed. With this magnet one is limited to using the same central angles on the left and right sides. However, any combination of polarities is possible.

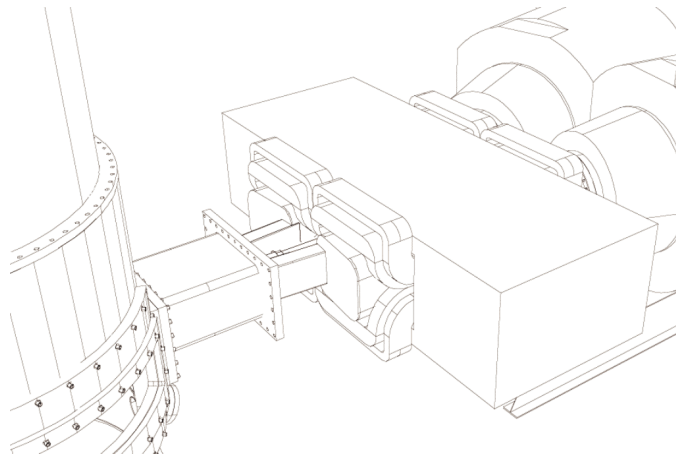

Figure 1: PREX Room Temperature septum magnet, 5° configuration, on the pivot with scattering chamber (foreground left) and HRS's (background right).

Since the PREX experiment relies on the physical separation of the elastic and first excited state (2.6 MeV) peaks of lead just behind the VDC's, a central concern in designing this magnet for the experiment was the preservation of good hardware resolution. Many iterations of TOSCA [1] calculations followed by raytracing with SNAKE [2] through the TOSCA generated septum maps and the HRS magnets for varying magnet configurations ultimately gave the momentum resolution illustrated in Figure 2. Achieving this very good hardware resolution for PREX will require a special low field configuration of the magnet where the central momentum at 5° will be limited to just over 1 GeV/c. Going to higher fields will require the removal of some iron filler pieces and the addition of a supplemental coil pack. In the higher field configuration hardware momentum resolution will be degraded by roughly a factor of two but central momenta of the order of 2 GeV/c at 5° will be achievable. The running parameters for this septum in the PREX experiment are shown in Table 1.

As of this writing, January 15, 2009, all major components have been designed and are ready to go or are already out for bids. The magnet and attendant systems are scheduled for installation in FY2010.

Table 1: Room temperature septum running parameters for the PREX experiment, 5° and 1.05 GeV/c.

p_0 (GeV/c)	$\int Bdl$	turns	I (amps)	current density
1.05	0.45 Tm	380	500	500 A/cm ²

References

- [1] TOSCA, 3-D Non-linear Magnetostatics Computer Program, Vector Fields, Oxford, England
- [2] P. Vermin, RPAC (II) CEBAF, January 1987, p.615

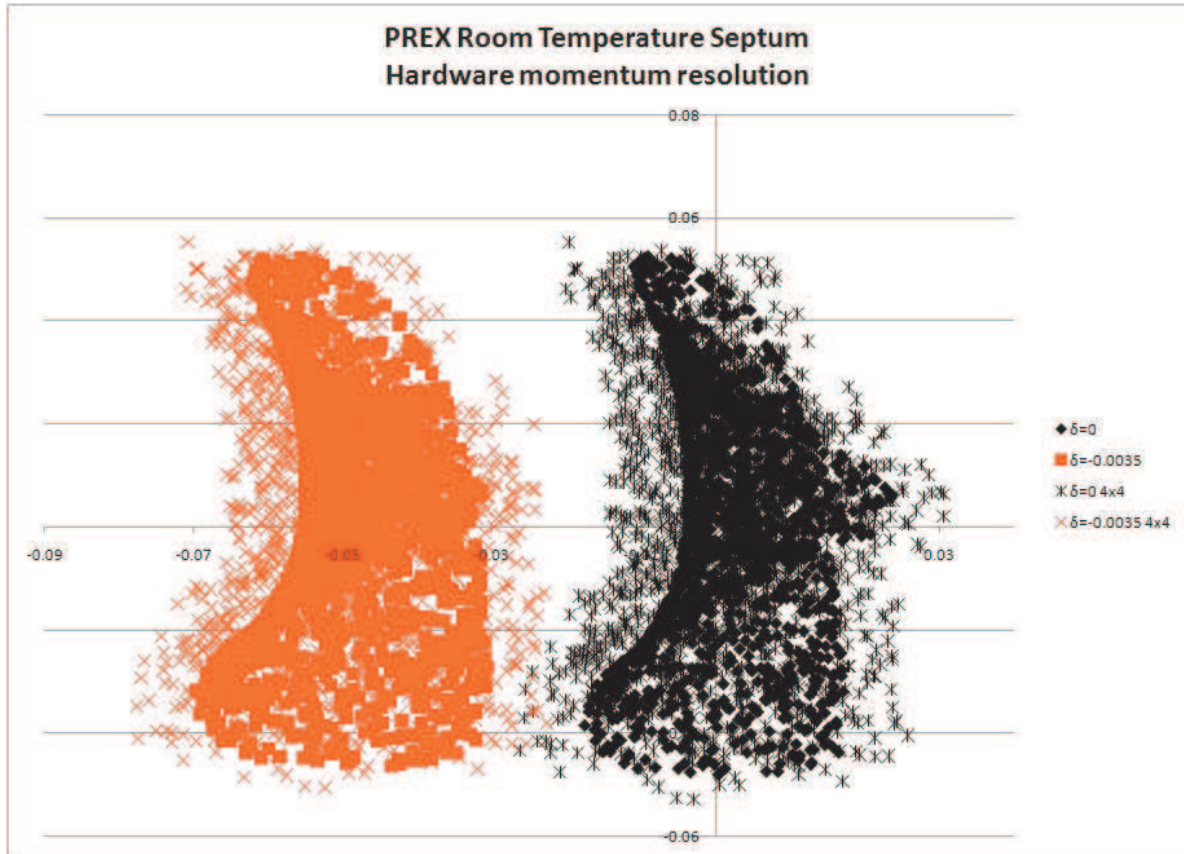

Figure 2: Monochromatic ray clusters traced using SNAKE at the HRS VDC. Black(red) solid symbols are for $\delta = 0$ ($\delta = -0.0035$). x's are the same but with a 4x4 mm raster. The horizontal and vertical axes are dispersive and transverse respectively. Units are meters.