

REVISION HISTORY				
ZONE	REV	DESCRIPTION	DATE	APPROVED

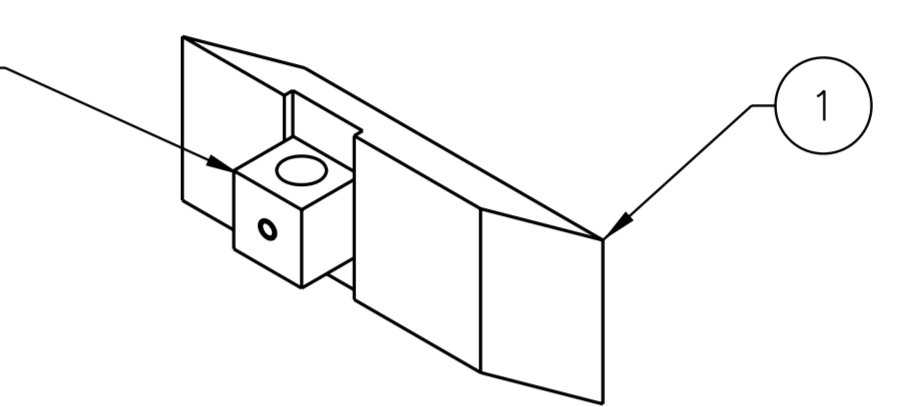

ISO VIEW 1-2C

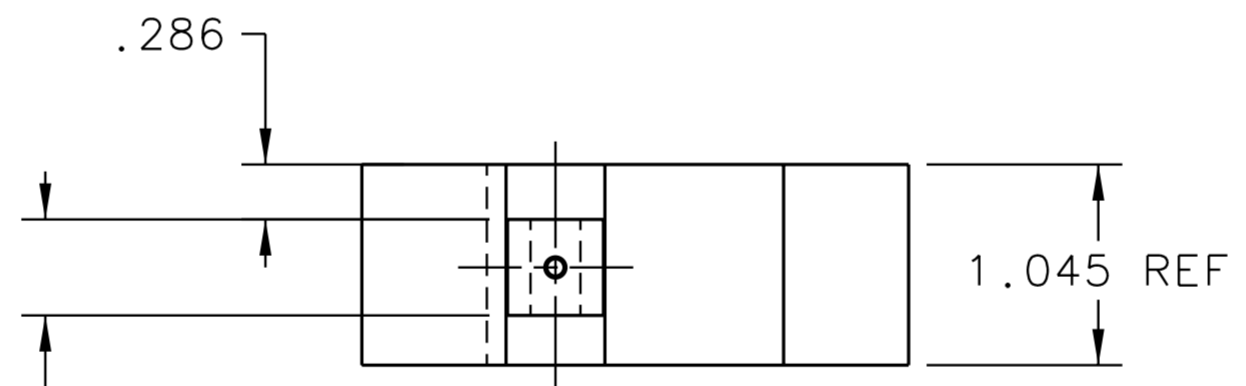

FRONT VIEW 1-4B

QTY REQD	ITEM NO.	PART OR IDENTIFYING NO.	NOMENCLATURE OR DESCRIPTION	MATERIAL SPECIFICATION	NOTES
1	2	A04018-03-01-1902	ADJUSTOR BLOCK	STAINLESS STEEL	-
1	1	A04018-03-01-1901	HRSBL FORWARD COLLIMATOR 21 DEG LOWER	HD17 DENSAMET	-

Jefferson Lab
 Thomas Jefferson National Accelerator Facility
 NEWPORT NEWS, VIRGINIA
 UNITED STATES DEPARTMENT OF ENERGY

DOCUMENT CONTROL STAMP		DIM & TOL PER ASME Y14.5 UNLESS OTHERWISE SPECIFIED DIMENSIONS ARE IN INCHES		TRACKING NO.		PARTS LIST	
SEE PARTS LIST		FRACTIONS: ± N/A DECIMAL: .X ± .1 .XX ± .01 .XXX ± .005 ANGLES: ± .50°		N/A		APPROVALS: J. MILLER DATE: 19SEP06	
FINISH MACHINED SURFACES UNLESS OTHERWISE NOTED DEBURR & BREAK ALL SHARP EDGES		THIRD ANGLE PROJECTION		DRAWN: J. MILLER CHECKED: A. GAVALYA APPROVED: P. BRINDZA APPROVED: J. COMEZ		HALL A - HE3HE4 TARGET - TARGET CELL LOWER HRSBL FORWARD COLL WLDMNT FOR LOWER	
DO NOT SCALE DRAWING				SCALE: 1:1 USED ON ASSY NO: A04018-03-01-1400		SIZE DWG. NO. C A04018-03-01-1900 REV. - SHEET 1 OF 1	