

Precision
Measurement of the
neutron d_2 : Towards
the Electric χ_E and
Magnetic χ_B Color
Polarizabilities

X. Zheng

Argonne National Laboratory, Argonne, IL 60439, USA

P. Bertin

Université Blaise Pascal De Clermont-Ferrand, Aubiere 63177, France

J.-P. Chen, E. Chudakov, C. W. de Jager, R. Feuerbach, J. Gomez, J. -O. Hansen,
D.W. Higinbotham, J. LeRose, W. Melnitchouk, R. Michaels, S. Nanda, A. Saha,
B. Wojtsekhowski

Jefferson Lab, Newport News, VA 23606, USA

S. Frullani, F. Garibaldi, M. Iodice, G. Urciuoli, F. Cusanno
Istituto Nazionale di Fisica Nucleare, Sezione Sanità, 00161 Roma, Italy

R. DeLeo, L. Lagamba

Istituto Nazionale di Fisica Nucleare, Bari, Italy

A.T. Katramatou, G.G. Petratos

Kent State University, Kent, OH 44242

W. Korsch

University of Kentucky, Lexington, KY 40506, USA

W. Bertozzi, Z. Chai, S. Gilad, M. Rvachev, Y. Xiao
Massachusetts Institute of Technology, Cambridge, MA 02139, USA

L. Gamberg

Penn State Berks, Reading, PA, 19610 USA

F. Benmokhtar, R. Gilman, C. Glashauser, E. Kuchina,
X. Jiang (co-spokesperson), G. Kumbartzki, R. Ransome
Rutgers University, Piscataway, NJ 08855, USA

Seonho Choi(co-spokesperson)

University of Seoul, Seoul, South Korea

B. Sawatzky (co-spokesperson), F. Butaru, A. Lukhanin,
Z.-E. Meziani (co-spokesperson), P. Solvignon, H. Yao
Temple University, Philadelphia, PA 19122, USA

S. Binet, G. Cates, N. Liyanage, J. Singh, A. Tobias
University of Virginia, Charlottesville, VA 22901, USA

D. Armstrong, T. Averett, J. M. Finn, K. Griffioen, T. Holmstrom, V. Sulkosky
College of William and Mary, Williamsburg, VA 23185, USA

Overview of Talk

- (Brief) Overview of d_2^n exper.

- ➔ Floor layout
- ➔ Kinematics
- ➔ BigBite Electron Package
 - ↳ Rates

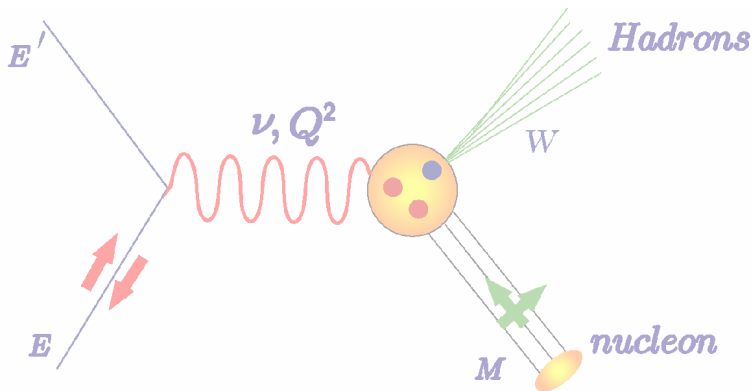

- New Cherenkov for BigBite

- ➔ Design
- ➔ Optics
- ➔ Backgrounds
- ➔ Radiator gas
 - ↳ gas system
- ➔ Mirrors
- ➔ Budget
- ➔ Timeline and Milestones
- ➔ Safety and Manpower

- Joint Commissioning Plan

- ➔ d_2^n + Transversity

Precision Measurement of the neutron d_2 : Towards the Electric χ_E and Magnetic χ_B Color Polarizabilities

Hall A Collaboration Experiment (Approved: PAC29)

- **Goal:**
Determine the neutron d_2 at $\langle Q^2 \rangle = 3 \text{ GeV}^2$

$$d_2^n(Q^2) = \int_0^1 x^2 [2g_1^n(x, Q^2) + 3g_2^n(x, Q^2)] dx$$

- **An Experiment in Hall A:**
 - ➔ A polarized electron beam of 4.6, 5.7 GeV and polarized ^3He target
 - ➔ Measure unpolarized cross section $\sigma_{\uparrow}^{^3\text{He}}$ for $^3\vec{\text{He}}(\vec{e}, e')$ in conjunction with the transverse asymmetry $A_{\perp}^{^3\text{He}}$ and the parallel asymmetry $A_{\parallel}^{^3\text{He}}$ for $0.2 < x < 0.65$ with $2 < Q^2 < 5 \text{ GeV}^2$.
- **Beamtime Allocation (PAC):**
 - ➔ **13 PAC** days to achieve a statistical uncertainty of $\Delta d_2^n = 5 \times 10^{-4}$

Floor configuration for this experiment

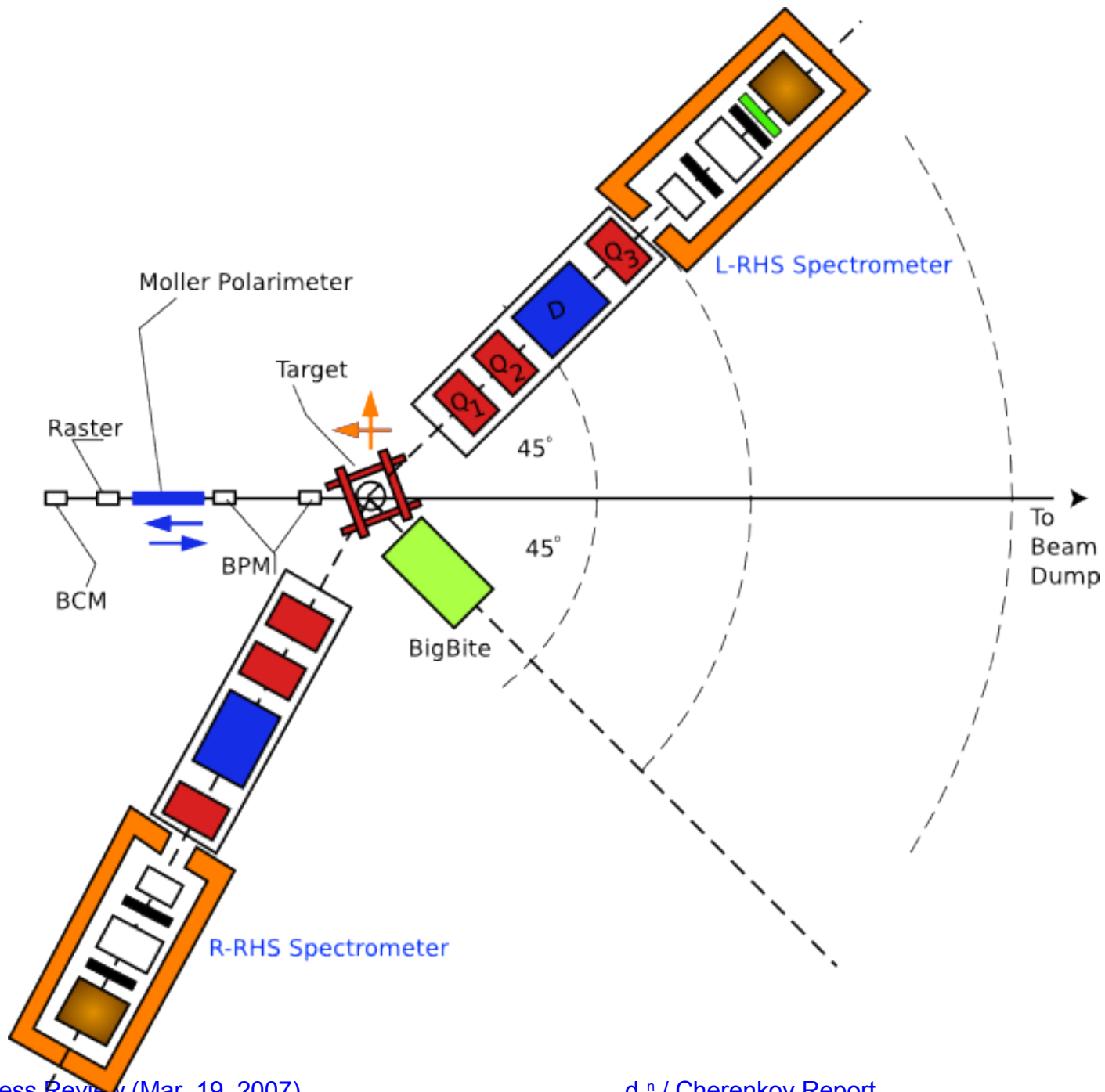

Kinematics of the measurement

- Two beam energies
4.6 and 5.7 GeV
(4 pass, 5 pass)
 - 80 hours at 4.6 GeV
 - 180 hours at 5.7 GeV
- BigBite fixed at single scattering angle ($\theta=45^\circ$)
(data divided into 10 bins during analysis).
 - Asymmetry meas.
- LHRS fixed at single scattering angle ($\theta=45^\circ$)
and stepped through 10 momentum settings.
 - Abs. cross section meas

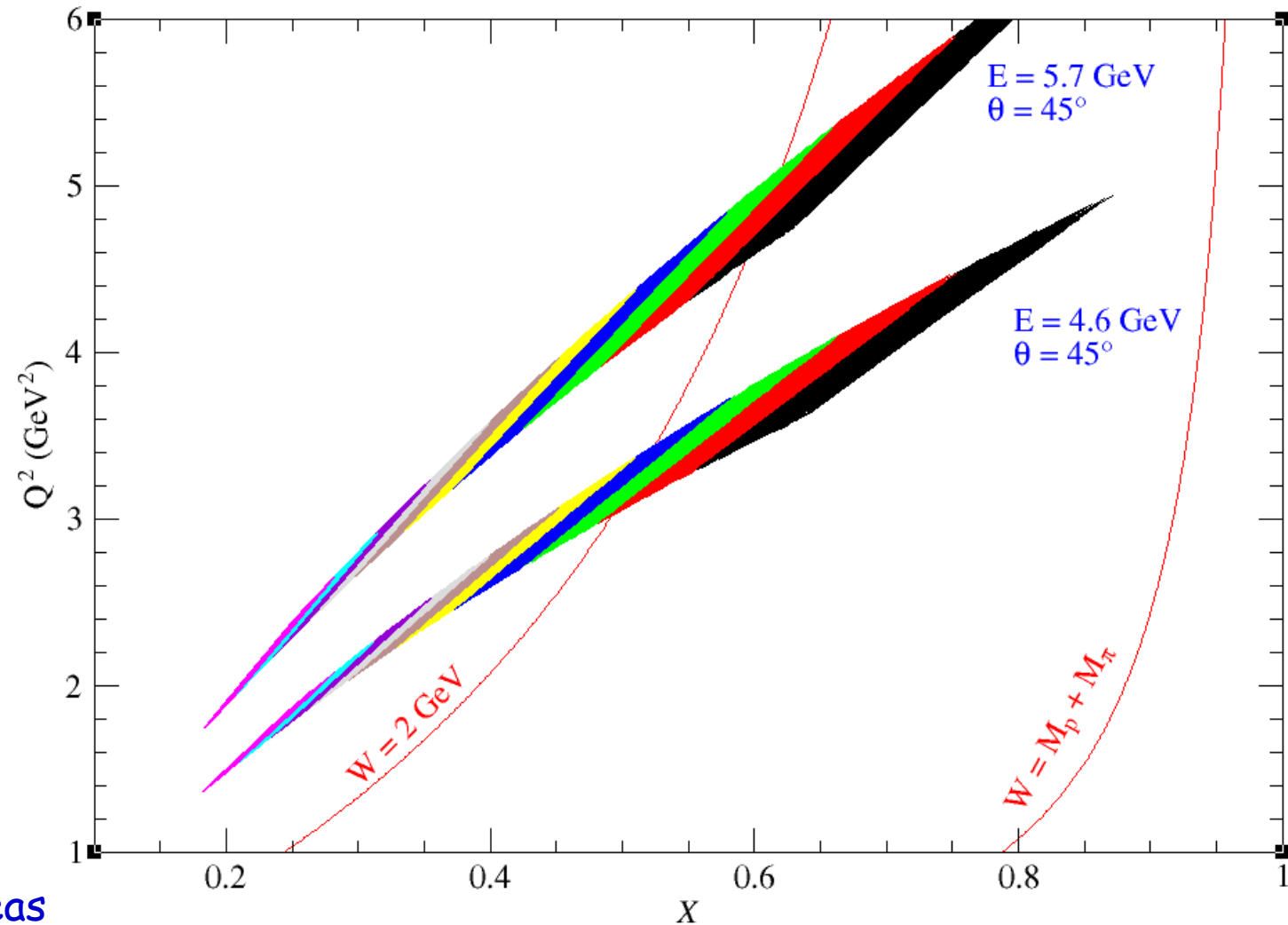

BigBite Configuration

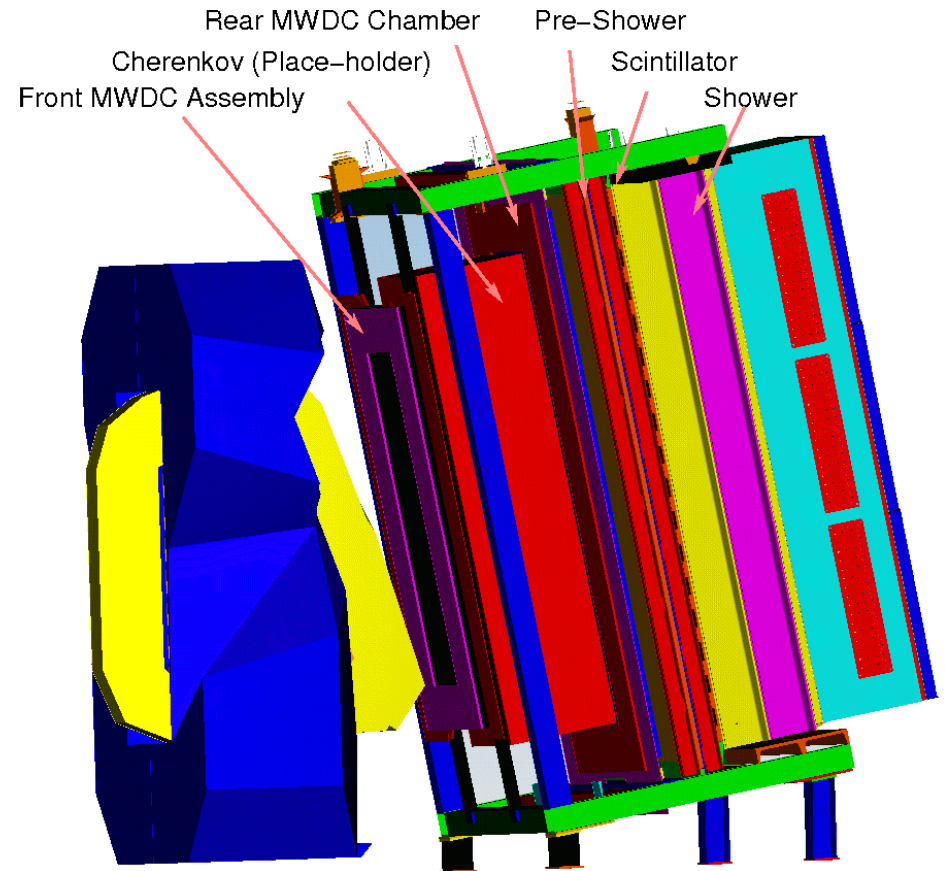
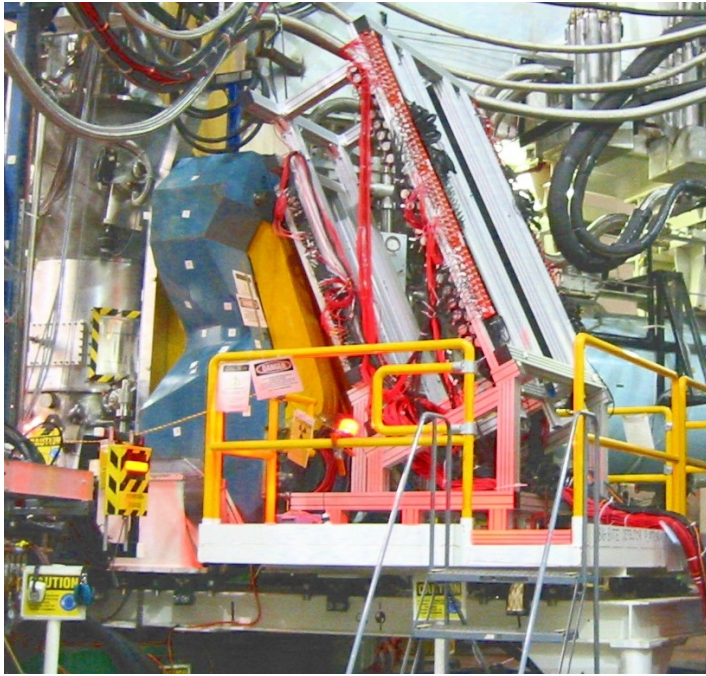

- Non-focusing, large acceptance, open geometry
- $\Delta p/p = 1 - 1.5\%$ (@ 1.2 T) $\sigma(W) = 50$ MeV
- angular resolution 1.5 mr, extended target resolution 6 mm
- large solid angle: ~ 64 msr
- detector package
 - ➔ 3 MWDCs, segmented trigger, Pb-glass shower
 - ➔ **Gas Cherenkov (new)**

Background Rates

- MC simulation by Degtyarenko et al. (tested in Halls A and C)
- Online cuts include:
 - BB magnet sweeps particles with $p < 200 \text{ MeV}/c$
 - GeN BB trigger: shower+pre-shower (Total energy)
 - ↳ ~550–600 MeV threshold on shower
 - 3–5 p.e. threshold on Cherenkov
 - ↳ heavily suppress random background
 - ↳ negl. pion contamination (~100 Hz knock-ons)
- Total estimated trigger rate (GeN trig + Cherenkov): 2–5 kHz

Online
triggers

e^-	2-5 kHz
e^+	<1 kHz

π^-	90 kHz
π^+	90 kHz
p	50 kHz
n	50 kHz

Removed via
online cuts

Cherenkov Design Parameters

- Dimensions: 200cm x 60cm x 60cm
 - ➔ sandwiched between wire chambers
- Radiator gas: C_4F_{10}
 - ➔ $n = 1.0015$
 - ➔ π threshold: $2.51 \text{ GeV}/c$
 - ➔ ~ 25 photo-electrons / 40 cm electron track
 - ➔ Quartz PMT (Photonis XP4518)
 - ➔ mirror reflectivity: $\sim 90\%$, 10% loss at PMT-gas interface
- $>98\%$ efficient with 3-4 p.e. threshold
 - ➔ negl. pion contamination
 - ➔ **minimum** π/e rejection ratio $500:1$ online (probably better)

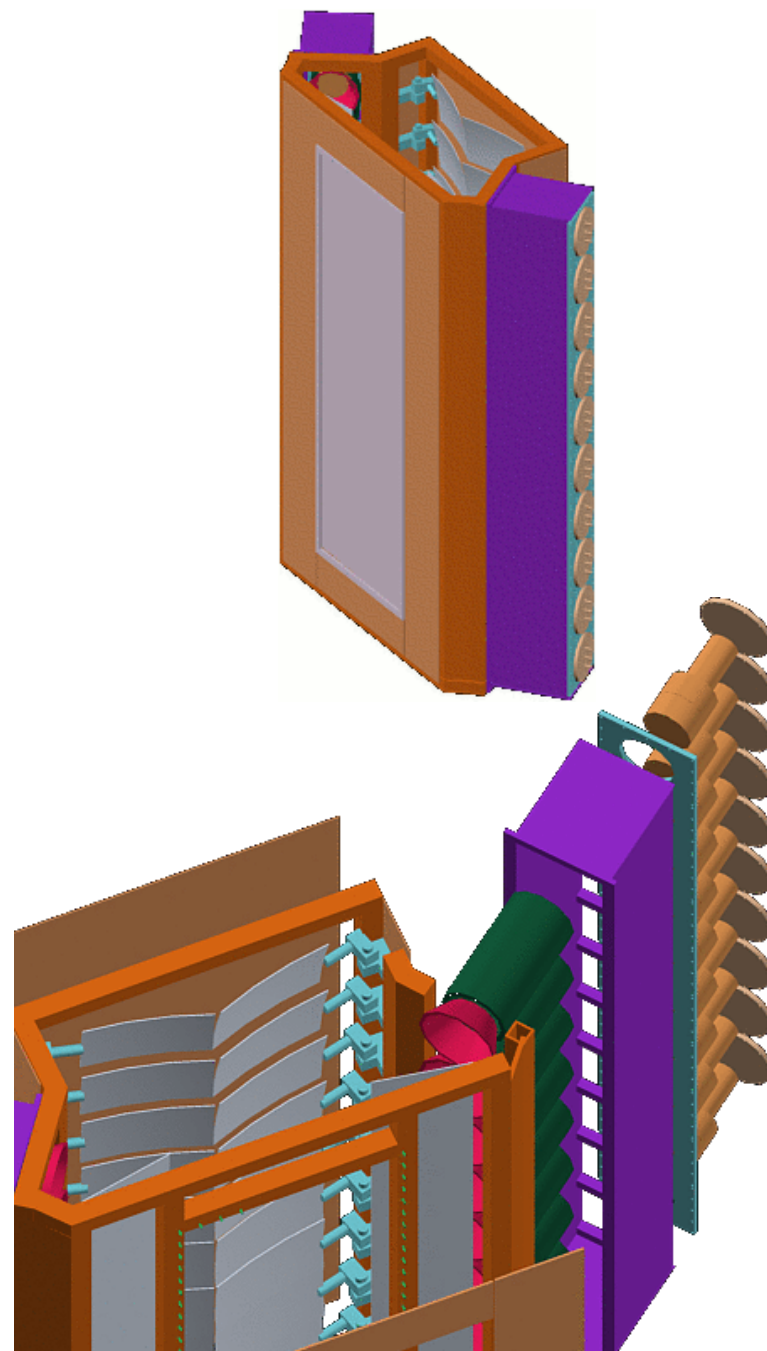

Cherenkov Frame

- Ed K. (Temple engineer) is developing CAD drawings
- Al Gavalya (JLab) is local contact for integration into BB Detector stack
- Details of mount to be finalized in next few weeks

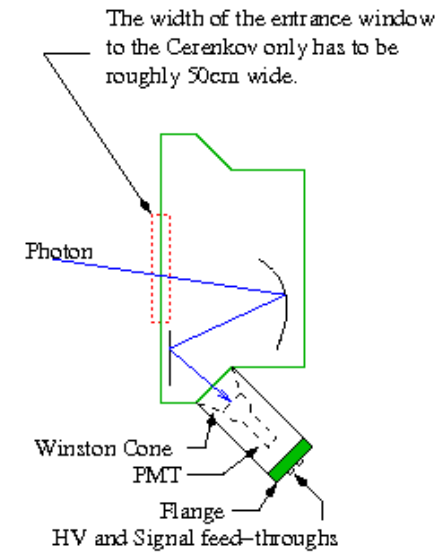
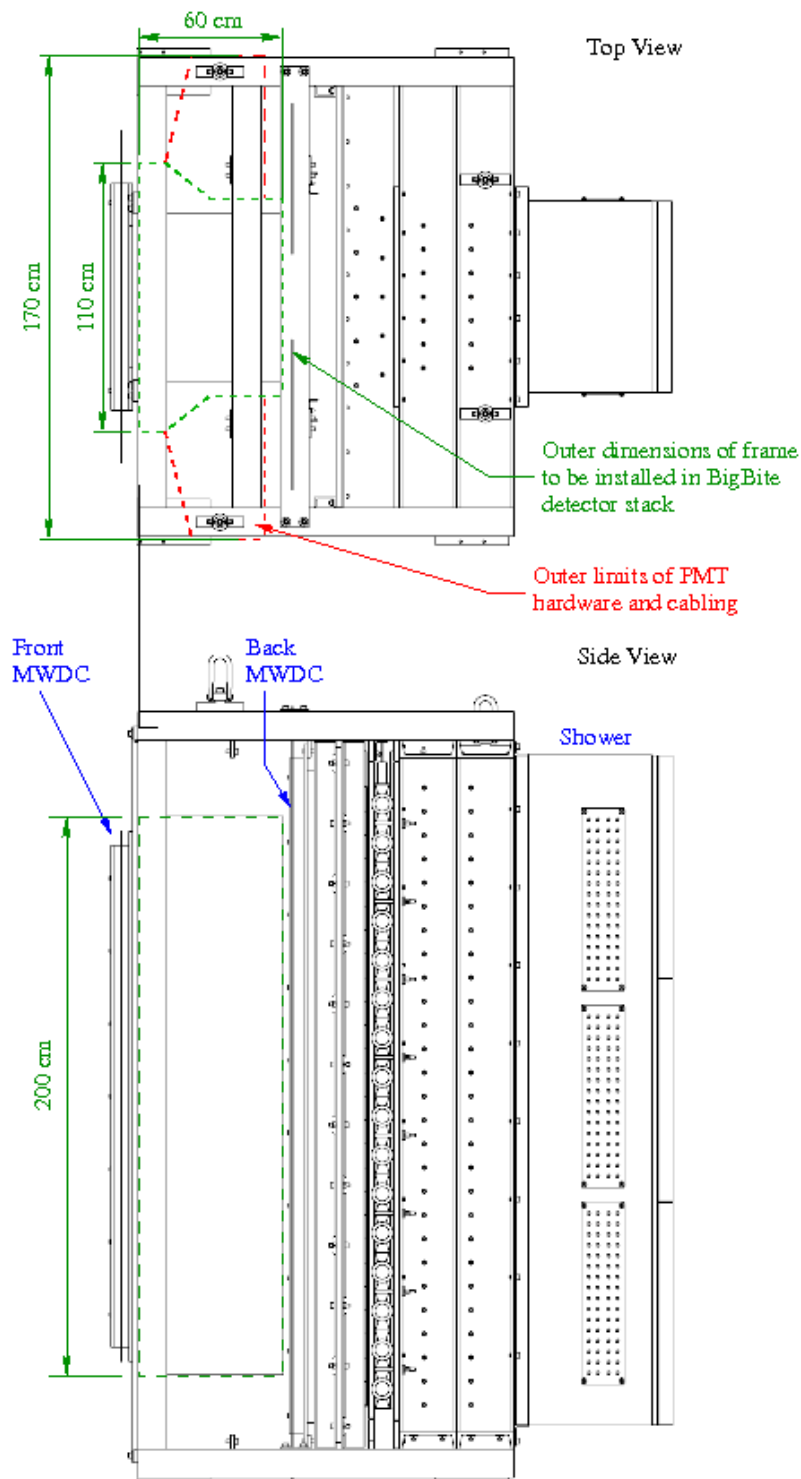
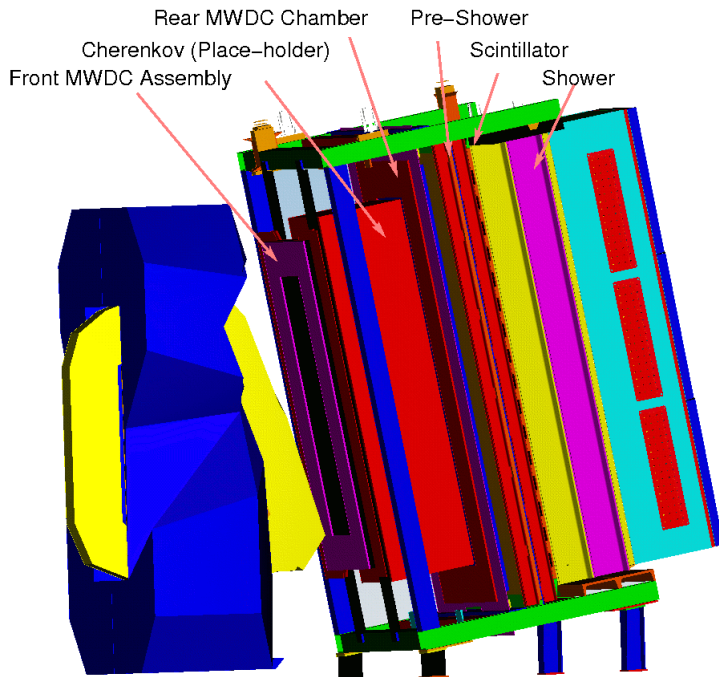

NOTE: The drawings are not necessarily to scale.

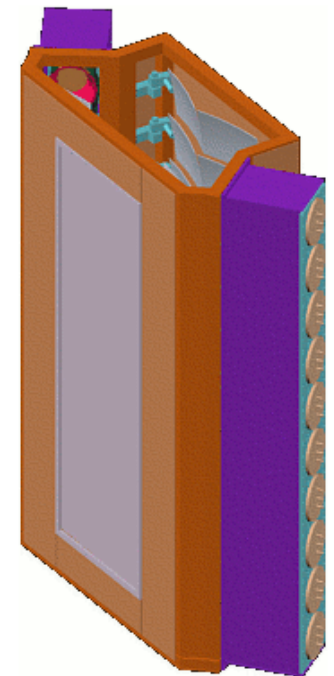

Cherenkov Optics

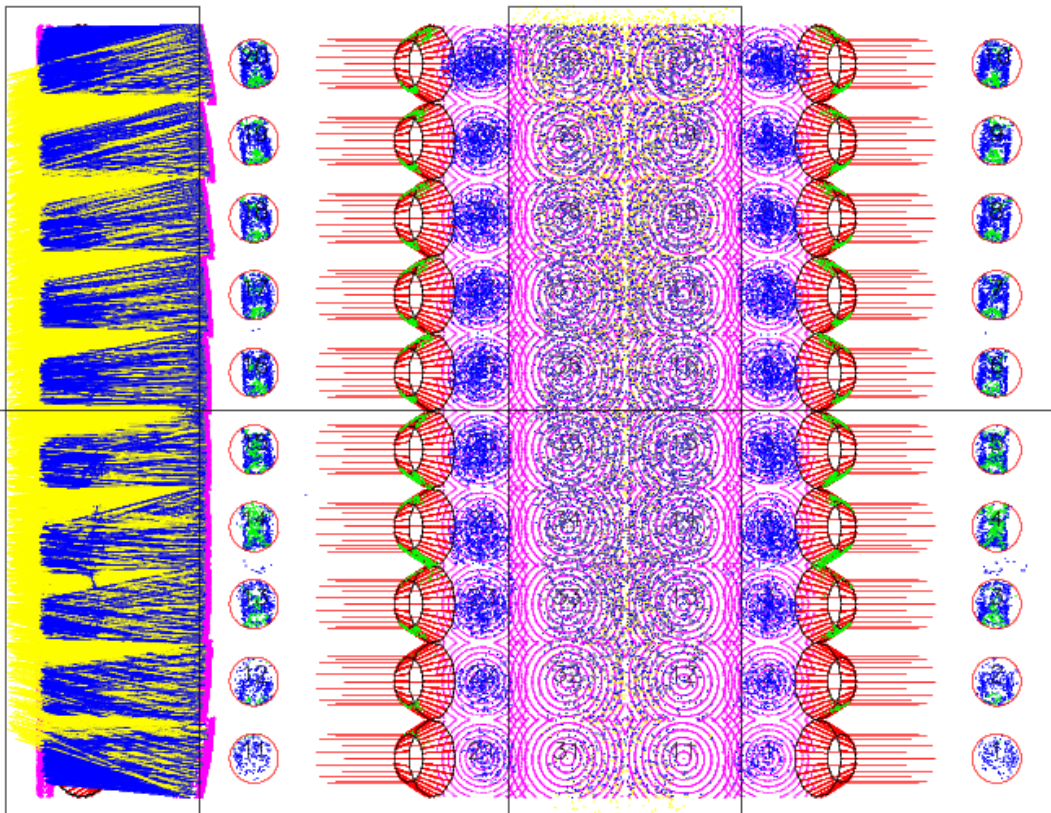
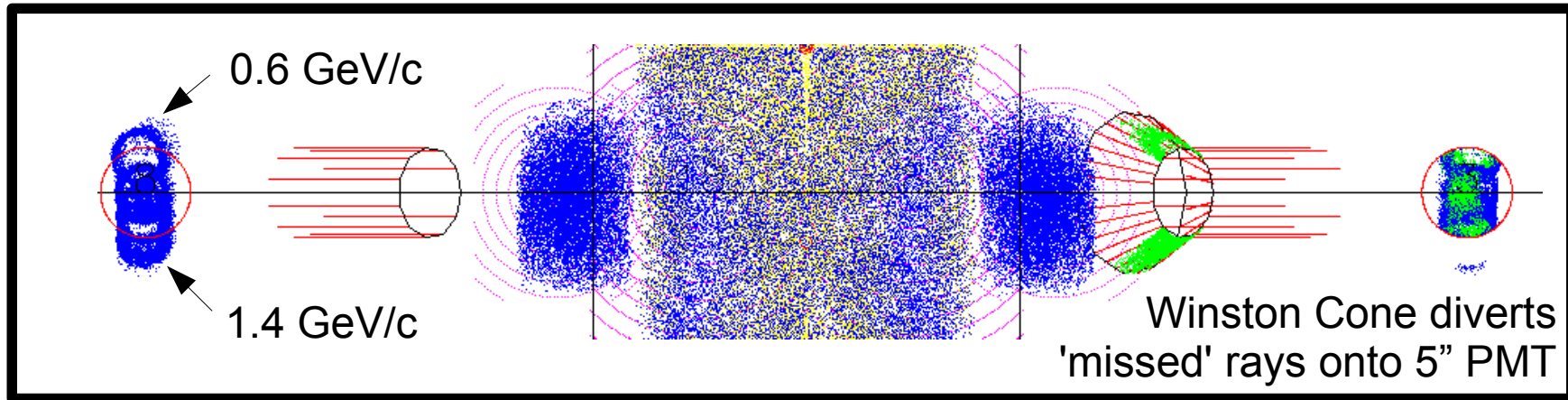
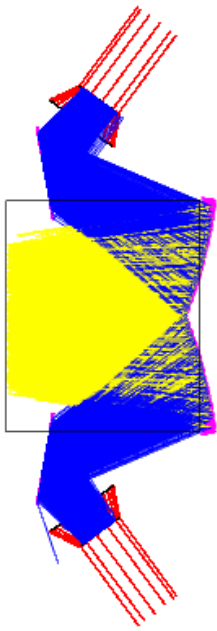

- Limited space required compact 2 mirror design
- Large BB momentum acceptance drove the need for pseudo-Winston Cones
 - ➔ low-mom. e^- focused higher
 - ➔ high-mom. e^- focused lower
- Ray trace models indicate > 95% collection efficiency with these optics

Background / Magnetic Field Effects on PMTs

- The effect of BigBite's residual magnetic field at the PMT location was empirically examined during GeN.
 - ➔ within mu-metal shield field dropped to <0.02 Gauss
 - ↳ also observed that the shielded PMT performance was independent of the PMT orientation within the the fringe field
- Background rates in bare PMT also studied during GeN
 - ➔ 3" quartz-face PMT was studied during GeN production runs
 - ↳ rate with 1" Al shielding and 3 p.e. discrim. threshold: ~ 1.8 kHz/ μ A
 - ➔ After scaling to account for 5" PMT and Transversity kinematics
 - ↳ rate with 1" Al shielding and 3 p.e. discrim. threshold: ~ 10 kHz/ μ A
 - ➔ For 100ns coinc. between 10 kHz Shower ANDed w/ 20 PMT Cerenkov
 - ↳ Worst case: 2 kHz random contribution
 - ↳ Segmented trigger (planned) will reduce rate by 5–10x
 - ➔ Anticipate < 400 Hz of randoms for d_2^n
 - ↳ should be conservative (d_2 at 45° , above estimates at 30°)

Cherenkov Gas Selection

- We will use C_4F_{10} at 1 atm
 - ➔ currently used in Hall B Cherenkov
- Detected photo-electron model assumes
 - ➔ 40 cm track in gas,
 - ➔ absorption losses in radiator,
 - ➔ scaled by 0.7 to accommodate losses at mirrors and PMT surface.
- Same model applied to current Hall A short Cherenkov reproduces measured p.e.'s to within 20%

Gas	n	e^- thr. (MeV/c)	π thr. (MeV/c)	Detected p.e.'s	
				Burle 8854	Quartz PMT
N ₂	1.0003	21	5926	3.2	5.4
CO ₂	1.0004	17	4671	5.4	9
Freon12	1.0011	11	2984	11	16
C ₄ F ₁₀	1.0015	9	2522	14	25

Gas System

- Tank pressure will be maintained at slightly above 1 atm.
 - ➔ relative underpressure compensated by fill from tank
 - ➔ relative overpressure vented
 - ➔ gas losses due to pressure compensation estimated to be 18 liters/day (roughly \$35/day at current pricing).

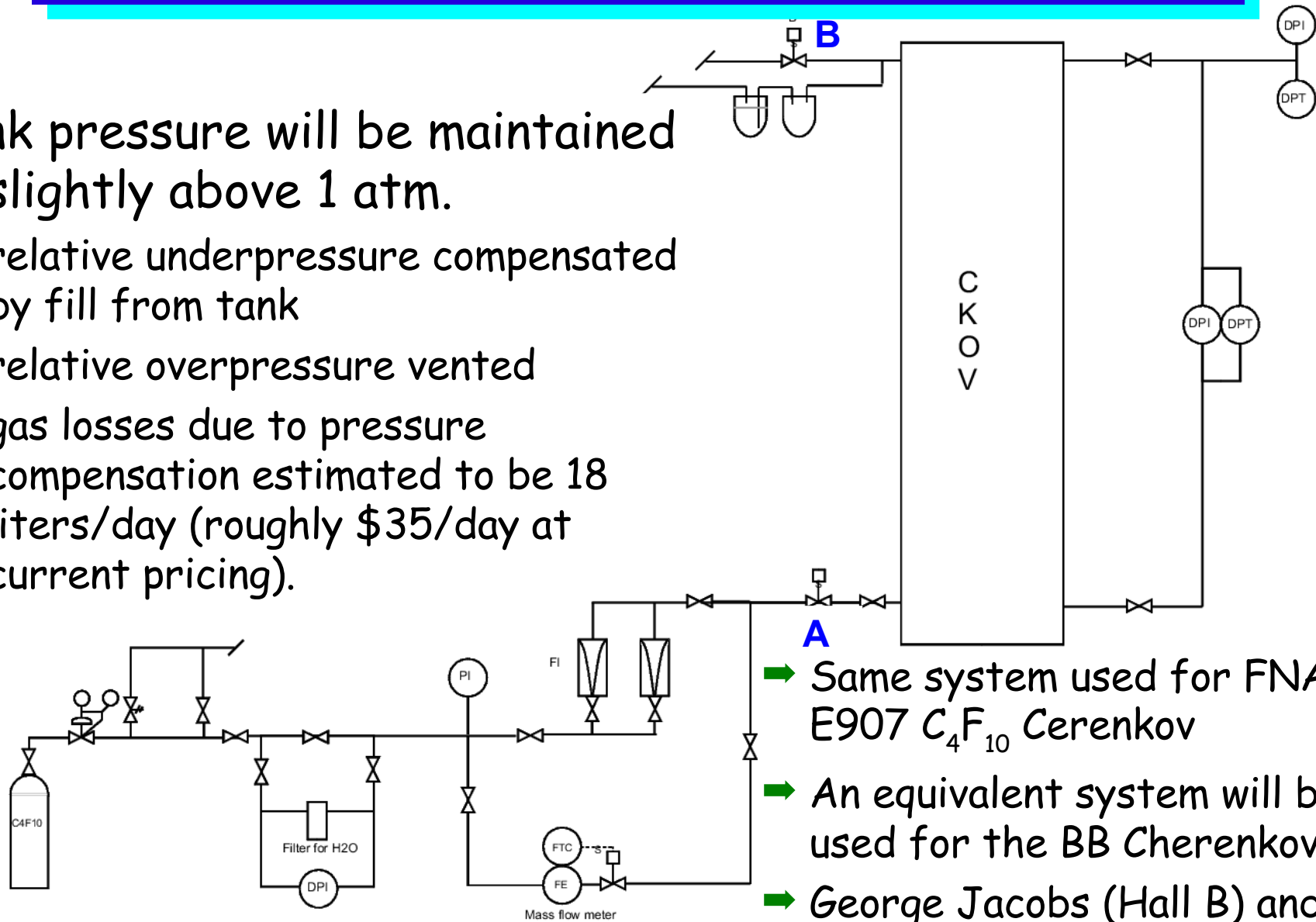

- ➔ Same system used for FNAL E907 C_4F_{10} Cerenkov
- ➔ An equivalent system will be used for the BB Cerenkov.
- ➔ George Jacobs (Hall B) and Jack Segal (Hall A) have reviewed this system.

Cherenkov Mirrors

- One complete, and one nearly complete option:
 - Model Optics (complete quote, but expensive: \$72k)
 - ↳ Quote for all three pieces (flat/spherical/conical)
 - ↳ Very expensive: ~\$1100/unit(!)
 - Cosmo Optics (Partial quote to date, but within budget)
 - ↳ Did mirrors for FermiLab Cherenkov (have experience)
 - ↳ Currently have quotes for 2 of 3 (flat and spherical) mirrors
 - (roughly $\frac{1}{2}$ cost of Model Optics quotes)
 - ↳ Developing quote for conical mirrors (end of March)
 - Best mixed-vendor cost (to date): **\$41k**
-
- Third possibility (under investigation)
 - Eagle Glass Specialties, Inc.
 - ↳ developed blanks for Hall C SANE Cherenkov
 - ↳ ~\$200/blank for spherical/flat mirrors, *not* coated
 - Coating done by CERN group
 - ↳ 'guaranteed/known' quality coating

Cherenkov Cost Breakdown

Component	Units	Cost/unit	Sub-total	\$ Source
Cerenkov frame/mounting hw/fittings			\$30.0k	Temple+JLab
Primary Mirrors (spherical) ¹	20+2	\$915	\$20.1k	Temple
Secondary Mirrors (flat) ¹	20+2	\$166	\$ 3.7k	+ Rutgers
Pseudo-Winston Cones ²	20+2	\$750	\$16.5k	+ JLab
PMT, base, μ -metal shield (UV glass)	20+2	\$3000	— ³	
Gas Handling System:			\$3–5k	JLab
C ₄ F ₁₀ gas: (cost/fill ⁴)		\$3500	—	Temple
Daily consumption		\$35/day	—	JLab

¹Feb. 2007 quote from Cosmo Optics, Middletown, NY, 845-343-9831.

²Feb. 2007 quote from Model Optics, Woodstock, NY, 845-679-7386. A quote on this part from Cosmo Optics is pending. See Section 8.2 for more detail.

³12 XP4508 PMTs + base were purchased by Hall A for use with the BigBite Cerenkov. Arrangements have been made to acquire 12–15 of the 5” quartz-face PMTs purchased for the G0 Cerenkov.

⁴A fill is estimated to be 1800 liters priced at US\$195/kg (1 kg liquid = 100 liters gas at STP) (Synquest Labs: Nov 20, 2006).

- Total if ordering today: ~ \$80k
 → final cost should be 10–15% less

Cherenkov Budget

- Total if ordering today: ~ \$80k
 - ➔ Hall A: \$60k for Cherenkov capital costs
 - ➔ Temple + Rutgers: \$20k
- Other contributions should lower final cost
 - ➔ Temple, Rutgers, Kentucky have University machine shops and have offered to take on some of the machining
 - ↳ free labor, just pay for materials
 - ➔ (These potential savings are *not* included in the \$80k)

Cherenkov Timeline and Milestones

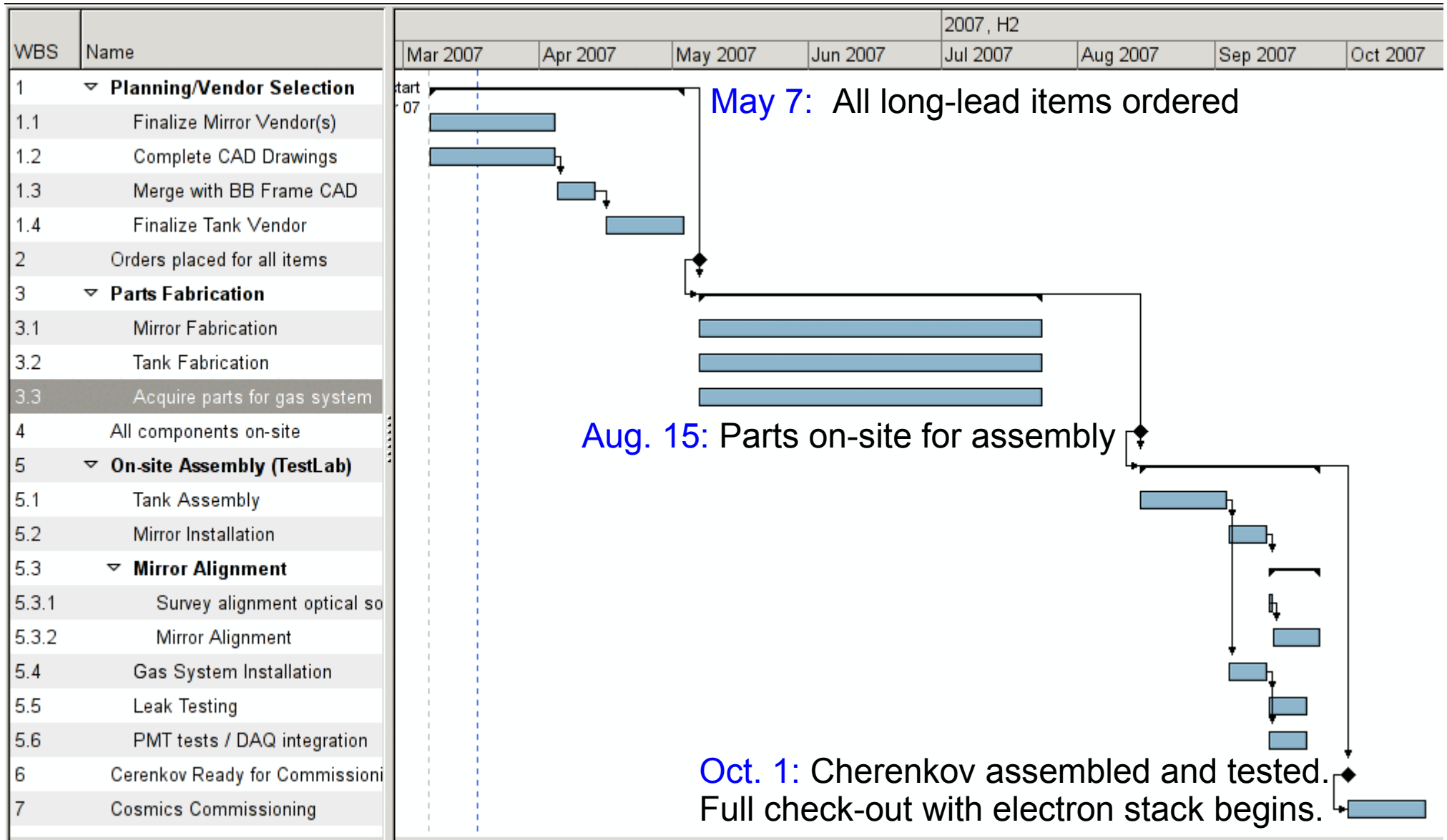

- Note: Fabrication and Assembly start times are keyed on Milestone dates, providing additional slack in schedule.

Safety Issues (Cherenkov)

- There are no special safety issues associated with the Cherenkov.
 - ➔ C_4F_{10} is chemically inert, non-toxic, non-flammable
 - ➔ Cherenkov operated at room temperature, 1 atm.
- There are no special rules associated with venting the C_4F_{10} into the atmosphere.
 - ➔ C_4F_{10} is classed as a greenhouse gas, but it is *not* an ozone destroyer
 - ➔ Our total consumption (with venting) is $\sim 1/6$ of Hall B's leakage rate.
- Brad Sawatzky will be in charge of the EH&S documentation/paperwork for the Cherenkov.

Manpower for E06-014

- Manpower focused on Cherenkov and E06-014
 - ➔ Ed Kaczanowicz (Temple engineer)
 - ➔ Sasha Lukhanin (Temple technician)
 - ➔ Brad Sawatzky (Temple post-doc, **on-site**)
 - ➔ Huan Yao (Temple, PhD student for d_2^n experiment, **on-site**)
- Significant overlap between all members of the 'Big Family'
 - ➔ We're all committed to making the group of experiments work.

Joint Commissioning for Transversity/ d_2^n

- Transversity and d_2^n share the same target, LHRS, and BigBite configuration we plan to collaborate on commissioning
 - E05-011/012 and E06-014 will commit a combined total of 7 days from their beam allocations to supplement the 7 commissioning days on the tentative schedule
- 14 days of beam commissioning planned

Item Description
Møller Polarimeter Compton Polarimeter (if available) Target commissioning
Beam Properties Harp scans, Bull's Eye scan, Rastering limits, Beam energy measurement, Study impact of Target field on beam traj. (corrector mag. commissioning)
LHRS RICH calibration, reconstruction check Aerogel calibration Short gas Cerenkov calibration $\pi^+ / K^+ / p$ PID check w/ aerogel+RICH HRS Optics with sieve (1+2 pass) Polarized ^3He Elastic measurement (1 pass)
BigBite Rate dependencies on disc. thresholds Shower Energy calibration Cerenkov Energy calibration and threshold determination MWDC voltage and threshold determination MWDC geometry and drift-time calibration BigBite Optics calibration (1+2 pass) Polarized ^3He Elastic measurement (1 pass) Coincidence timing check with LHRS

Extra Slides

Photo-electron Yield

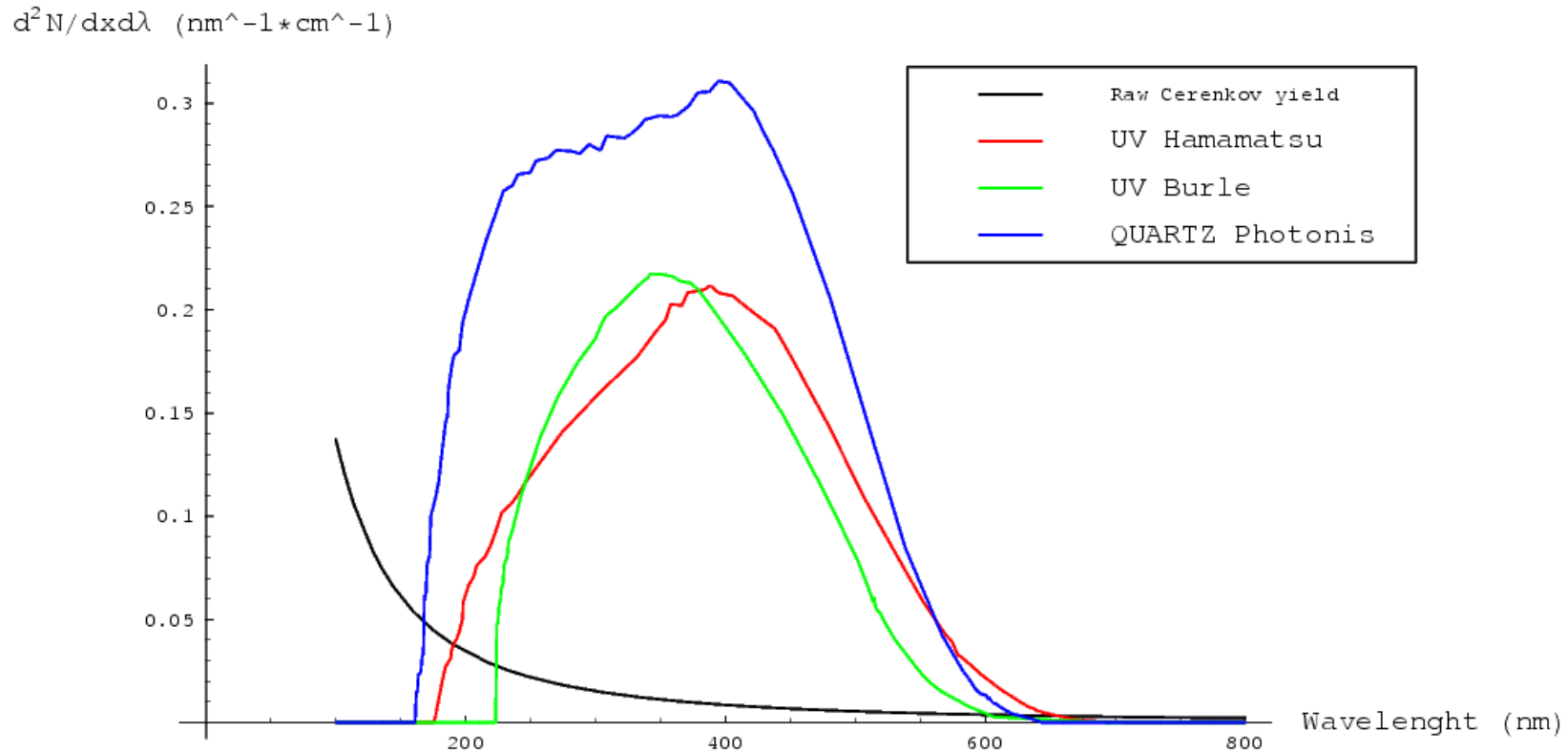

Figure 5: Differential photo-electron (p.e.) yield per wavelength (in nm) per unit distance in radiator (in cm). The three colored curves represent the quantum efficiencies (q.e.) of three characteristic 5" PMTs ((i.e.) p.e.'s per photon). The black curve is the raw Cerenkov differential photon yield. Integrating the product of the Cerenkov yield and the q.e. gives a first-order estimate of the PMT response to an electron track in the radiator.

Cherenkov Timeline and Milestones

WBS	Name	Start	Finish	Duration
1	▼ Planning/Vendor Selection	Mar 7	May 3	42d
1.1	Finalize Mirror Vendor(s)	Mar 7	Apr 4	21d
1.2	Complete CAD Drawings	Mar 7	Apr 4	21d
1.3	Merge with BB Frame CAD	Apr 5	Apr 13	7d
1.4	Finalize Tank Vendor	Apr 16	May 3	14d
2	Orders placed for all items	May 7	May 7	N/A
3	▼ Parts Fabrication	May 7	Jul 23	56d
3.1	Mirror Fabrication	May 7	Jul 23	56d
3.2	Tank Fabrication	May 7	Jul 23	56d
3.3	Acquire parts for gas system	May 7	Jul 23	56d
4	All components on-site	Aug 15	Aug 15	N/A
5	▼ On-site Assembly (TestLab)	Aug 15	Sep 24	29d
5.1	Tank Assembly	Aug 15	Sep 3	14d
5.2	Mirror Installation	Sep 4	Sep 12	7d
5.3	▼ Mirror Alignment	Sep 13	Sep 24	8d
5.3.1	Survey alignment optical source	Sep 13	Sep 13	1d
5.3.2	Mirror Alignment	Sep 14	Sep 24	7d
5.4	Gas System Installation	Sep 4	Sep 12	7d
5.5	Leak Testing	Sep 13	Sep 21	7d
5.6	PMT tests / DAQ integration	Sep 13	Sep 21	7d
6	Cherenkov Ready for Commissioning	Oct 1	Oct 1	N/A
7	Cosmics Commissioning	Oct 1	Oct 18	14d

Systematic Error Contributions to d_2^n

Item description	Subitem description	Relative uncertainty
Target polarization		3 %
Beam polarization		3 %
Asymmetry (raw)	<ul style="list-style-type: none"> • Target spin direction (0.1°) • Beam charge asymmetry 	$< 5 \times 10^{-4}$ $< 50 \text{ ppm}$
Cross section (raw)	<ul style="list-style-type: none"> • PID efficiency • Background Rejection efficiency • Beam charge • Beam position • Acceptance cut • Target density • Nitrogen dilution • Dead time • Finite Acceptance cut 	$\approx 1 \%$ $\approx 1 \%$ $< 1 \%$ $< 1 \%$ $2\text{-}3 \%$ $< 2\%$ $< 2\%$ $< 1\%$ $< 1\%$
Radiative corrections		$\leq 5 \%$
From ^3He to Neutron correction		5 %
Total systematic uncertainty		$\leq 10 \%$
Estimate of contributions to d_2 from unmeasured regions	$\int_{0.003}^{0.23} \tilde{d}_2^n dx$ $\int_{0.70}^{0.999} \tilde{d}_2^n dx$	4.8×10^{-4} 5.0×10^{-5}
Projected absolute statistical uncertainty on d_2		$\Delta d_2 \approx 5 \times 10^{-4}$
Projected absolute systematic uncertainty on d_2 (assuming $d_2 = 5 \times 10^{-3}$)		$\Delta d_2 \approx 5 \times 10^{-4}$

Kinematics of the measurement

E_i (GeV)	bin central p (GeV)	x	Δx	Q^2 (GeV ²)	W (GeV)	Rate (Hz)	
5.700	1.603	0.696	0.097	5.35	1.79	3.0	
5.700	1.450	0.607	0.081	4.84	2.00	5.0	
5.700	1.312	0.532	0.069	4.38	2.18	7.0	
5.700	1.187	0.468	0.059	3.96	2.32	8.9	Single
5.700	1.074	0.413	0.051	3.59	2.44	10.4	BigBite
5.700	0.971	0.365	0.044	3.24	2.55	11.6	Spectrometer
5.700	0.878	0.324	0.038	2.93	2.65	12.5	Setting
5.700	0.794	0.288	0.034	2.65	2.73	13.1	
5.700	0.718	0.256	0.029	2.40	2.80	13.5	
5.700	0.650	0.229	0.026	2.17	2.86	13.8	
						Time _⊥	Time _∥
						hours	hours
Total (5.7 GeV data set)						172	8

- **L-HRS** used to measure total cross section at **10 momentum settings**.
 ➔ will also reverse the field to monitor π/π^+ and e^-/e^+ asymmetries
- **BigBite** takes all asymmetry data with **single setting**.
 ➔ Optimized to minimize error on d^2
- **180 hours** for **5.7 GeV** data set

Kinematics continued...

E_i (GeV)	bin central p (GeV)	x	Δx	Q^2 (GeV ²)	W (GeV)	Rate (Hz)	
4.600	1.502	0.696	0.118	4.05	1.63	4.22	
4.600	1.366	0.607	0.097	3.68	1.81	7.95	
4.600	1.243	0.532	0.080	3.35	1.96	10.8	
4.600	1.131	0.468	0.067	3.05	2.08	14.1	Single
4.600	1.028	0.413	0.057	2.77	2.19	16.8	BigBite
4.600	0.933	0.365	0.049	2.51	2.29	18.9	Spectrometer
4.600	0.847	0.324	0.042	2.28	2.38	20.3	Setting
4.600	0.768	0.288	0.036	2.07	2.45	21.3	
4.600	0.696	0.256	0.032	1.88	2.52	21.8	
4.600	0.633	0.229	0.028	1.71	2.57	22.0	
						Time _⊥	Time _∥
						hours	hours
Total (4.6 GeV data set)						72	8

- L-HRS used to measure total cross section at 10 momentum settings.
 - BigBite takes all asymmetry data with single setting.
 - ➔ Focus is measuring Q^2 evolution of $x^2 \bar{g}_2$
 - +80 hours for 4.6 GeV data set
 - ➔ add 48 hours calibration and overhead
- ➔ **TOTAL: 308 hours (13 days)**

DAQ Diagrams for d_2^n / Transversity

Coincidence Timing (Transversity)

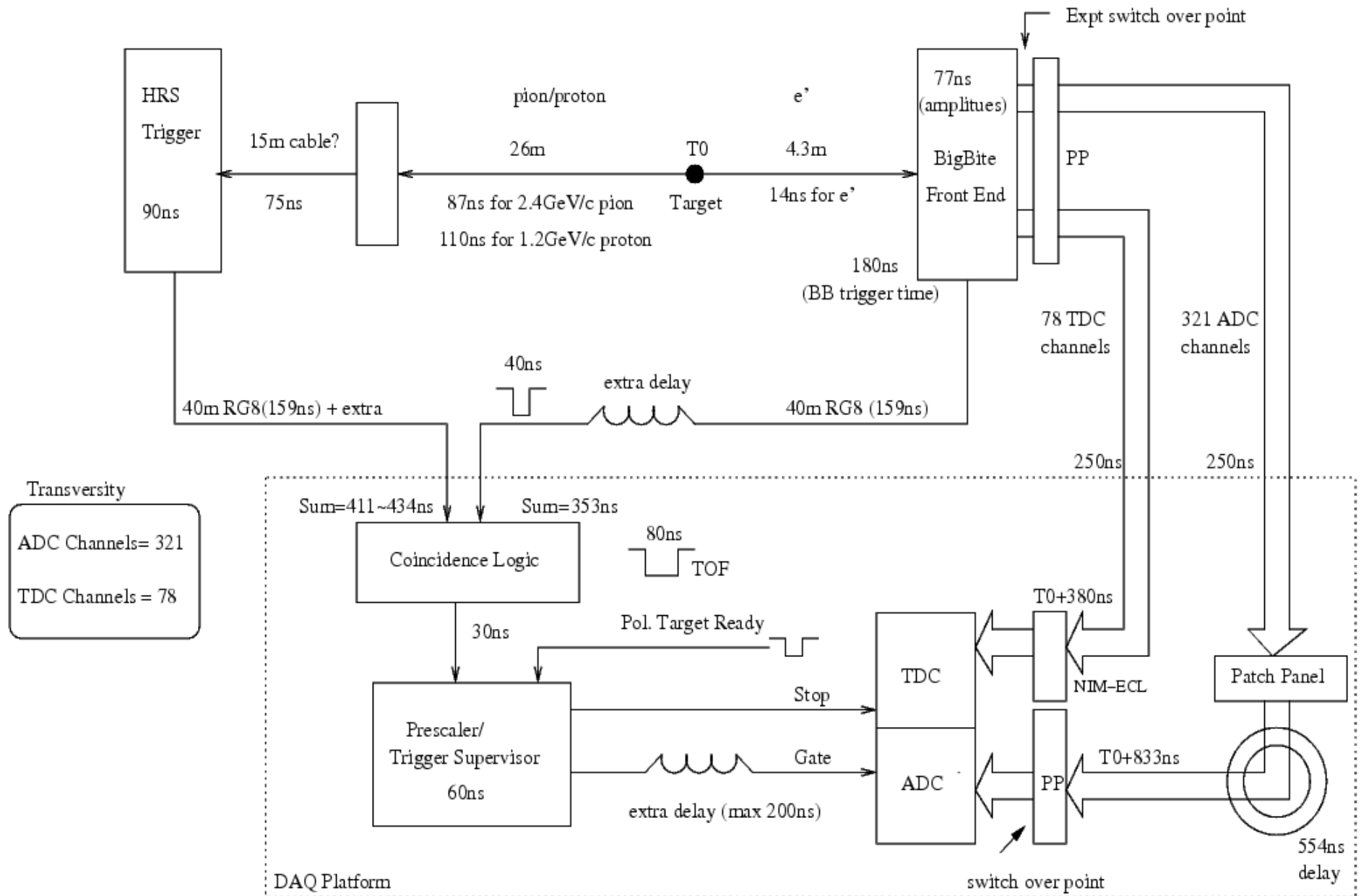

BigBite Cherenkov Trigger

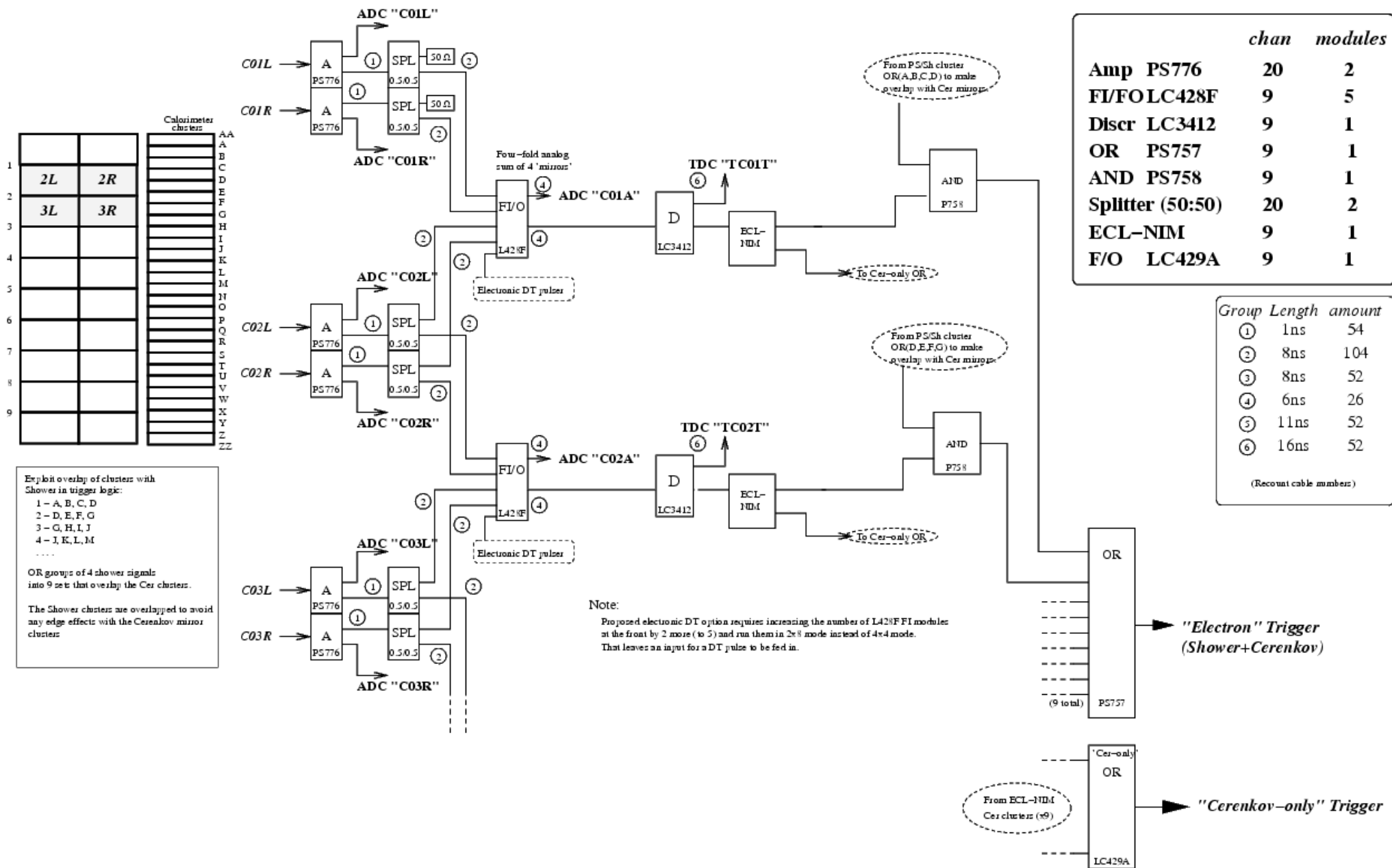

BigBite Rack Layout

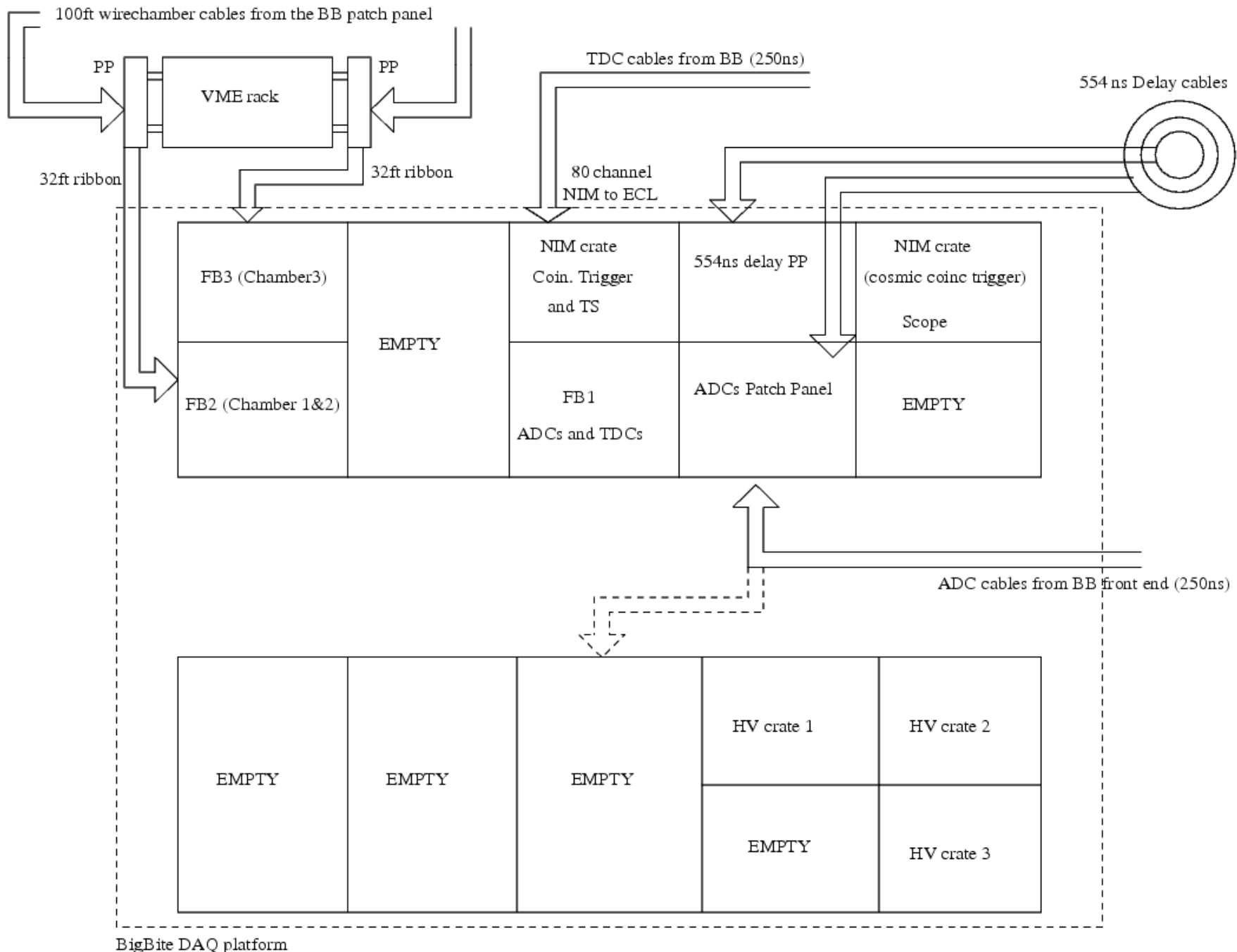

BigBite DAQ platform

BigBite Cherenkov + Shower/PreSh Geometric Overlap

9 Cher. Mirror sums
(2 rows/group)

Side View
(To scale)

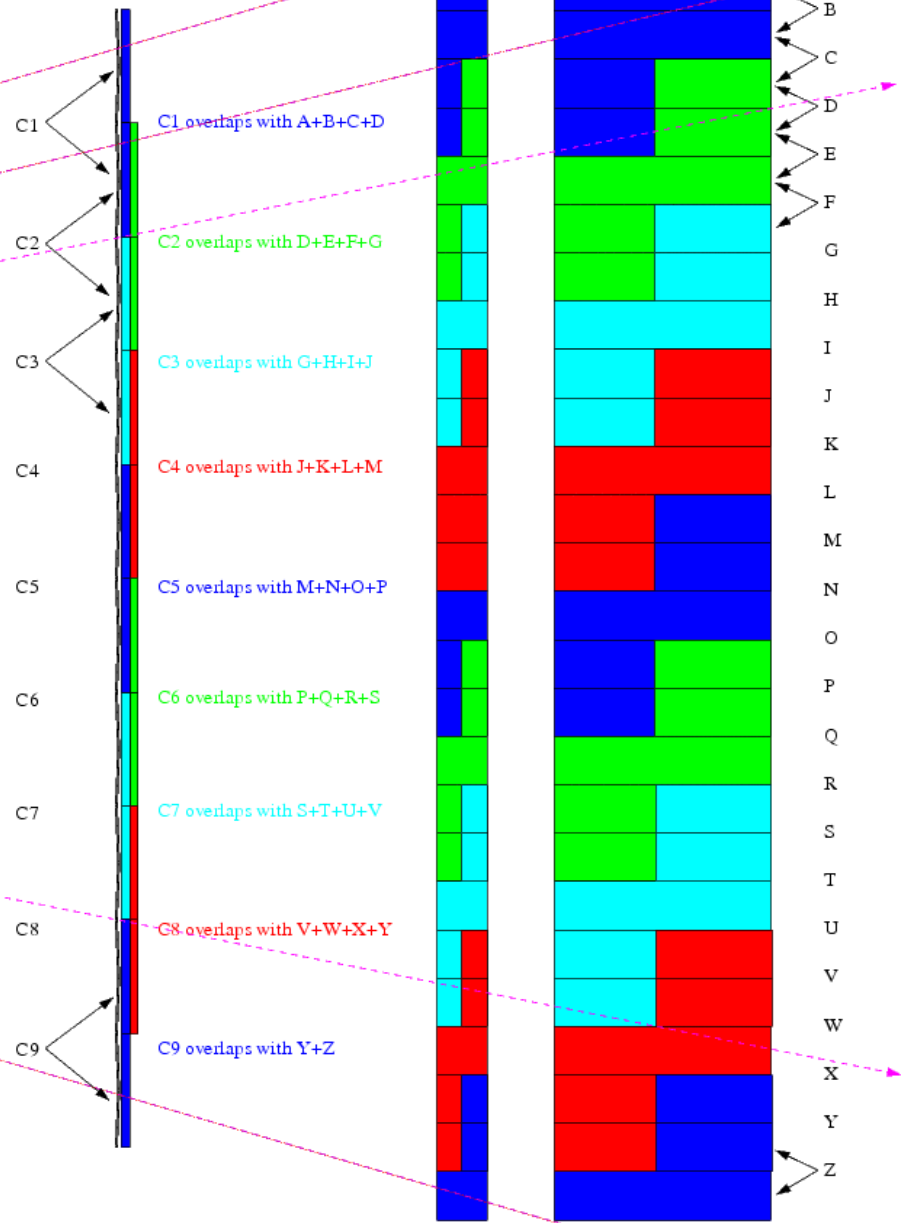

26 Sh+PS group-sums (2 rows/group)