

Hall A Status Update

Thia Keppel
Hall A Collaboration Meeting
June 2013

Accelerator schedule excerpts (Arne Freyberger) - *unchanged at present**

- Accelerator Run II: Beam in hall ~2/2014
 - > 1.1 GeV/pass, 3 pass spin-up to Hall A
 - up to 5.5 pass to D by ~5/14
 - Shut down 5/3/14
- Accelerator Run III: 8/30/14 – 12/1/14
 - CD4A milestones
 - 12 GeV 5.5 pass capable *installed*
 - 11 GeV 5 pass to A, B, C *installed*
 - > 2 nA 2.2 GeV single pass *transported*
 - Plan
 - E > 2 GeV/pass, 10 GeV to Hall D
 - 2 Hall operation
- Accelerator Run IV: 2/13/15 – 6/1/15
 - E > 2 GeV/pass, 2 hall operation
 - CD4B Halls B,C,D operational, > 6, 6, 10 GeV
- Physics Run I: 8/30/15 – 12/23/15
 - E > 2 GeV/pass
- Physics Run II: 2/6/16 – 6/25/16
- Physics Run III: 9/12/16 – 12/22/16
- Spring, fall, spring, fall runs continue....

**Rebaseline
plans being
finalized*

Accelerator schedule – first considerations for Hall A

- Accelerator Run II: 2/2014 – 5/3/14
 - Beam energy may be increasing, tune will likely not be beautiful to start
 - Need to demonstrate/test/measure beam energy, polarization, position, angle on target, current, spot size, raster
 - Detector and DAQ checkout – HRS's a priority
 - Won't have beam constantly, accelerator work is priority
 - Try to run for physics anyway! ☺
 - Should be ready with experiment(s) on the floor
- Accelerator Run III: 8/30/14 – 12/1/14
 - Beamline and tune should be ~OK
 - 11 GeV (or close-ish) - physics could really begin
- Assume at least these two accelerator runs will have to be combined
 - Starting “simple”
 - Use HRS's, hydrogen target
 - Likely enough work to do and problems to diagnose with the new beam line, tune, and instrumentation: Work with the known to troubleshoot the unknown
 - Flexible experiment(s) that can use both low and high E beams
 - Experienced collaboration(s)

Hall A Projected Experiment Schedule as of 8/2012

	February - May	August - December	February - June	August - December	February - June	September - December
2014	GMp / DVCS - I	GMp / DVCS - I				
2015			${}^3\text{H}/{}^3\text{He}$ (A_1^n)	PREX (APEX)		
2016					A_1^n (SBS) (DVCS-II) (APEX)	SBS (A_1^n) (DVCS-II) (APEX)

Experiments in parentheses represent potential schedule changes.

available on Hall A wiki

SBS



MOLLER,
SOLID...?.....

Hall A Projected Experiment Schedule as of 6/2013

	Spring	Fall	Spring	Fall	Spring	Fall	Spring
2014	DVCS -I/ GMp	DVCS - I/ GMp					
2015			DVCS - I/ GMp	$^3\text{H}/^3\text{He}$ (A_1^n)			
2016					A_1^n (APEX) (PREX)	PREX (APEX) (DVCS-II)	
2017							APEX (DVCS- II) (SBS)

Experiments in parentheses represent potential schedule changes.

SBS
→

...soon to be available on Hall A wiki

MOLLER,
SOLID...?....

- 
- The Hall is not *practically* badly backlogged yet.
 - There may be more to add (PAC40)....

Proposals:

PR12-013-002, hypernuclear physics

PR12-013-006, CREX

PR12-013-012, $^3\text{H}(e,e2p)$

Letters of Intent

LOI12-013-001, SOLID timelike Compton

LOI12-013-004, 3H elastic

LOI12-013-002, SOLID di-hadron

Near Term Hall Upgrades and Modifications

- Beamline
 - Compton Polarimeter
 - Moller Polarimeter - room temp + superconducting
 - BCMs, BPMs, Unser
 - Raster
 - Arc Energy
- Cryotarget
 - + Swing Arm for Optics Centering
 - Scattering Chamber + Extension
- Detectors
 - HRS repairs and upgrades
 - Cerenkov, additional tracking plane
 - DVCS Calorimeter Shielding + Stand
 - Improve DVCS cable mobility
- HRS Cooldown in Fall 2013



*NOT a
comprehensive
list*

*LOTS of room
for help!!!*

DVCS-I* / G_M^p Combined Run

- G_M^p largely backward angle, high Q^2 : HRS-R
 - May need some short running at forward angle, lower Q^2
- DVCS entirely forward angle: HRS-L + calorimeter
 - Plan to put calorimeter on the floor summer 2014 (between Accel. Runs II, III)
- Design is complete for target chamber/extension design, calorimeter stand modifications
- Still working on target, current issues
- Working on beam diagnostics
 - Plus energy measurements with HRS?
- Need to plan in detail for commissioning

*For DVCS anticipate a two run approach (100 days approved) to obtain full kinematic range

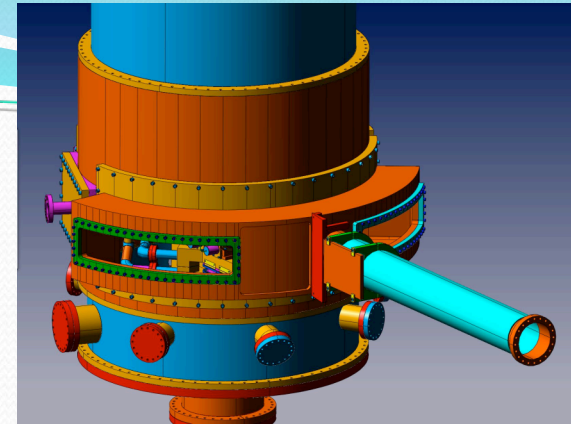

E12-06-114: DVCS scaling in Hall A

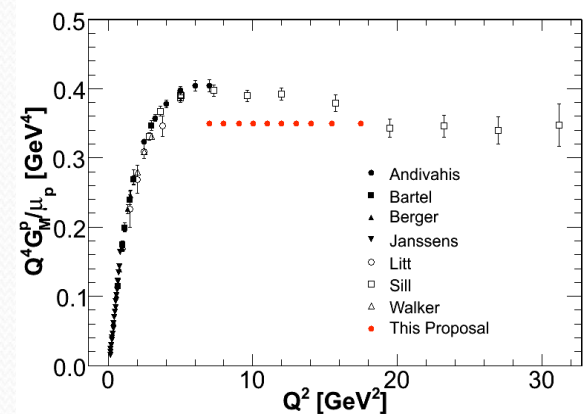
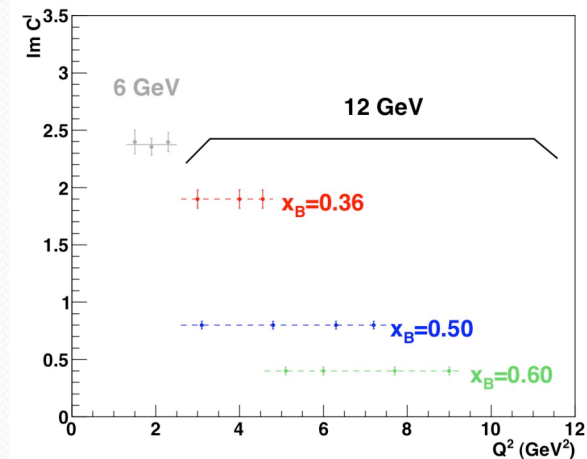

$^3\text{H}/^3\text{He}$ Experiments

- Tritium cell development
- Test cell factor ~10 safety test, burst pressure above 3500 psi
- Working on safety and venting systems for hall
- BigBite will be put back together - *with modifications* - in new test lab space
 - Cerenkov design and improvements
 - GEMs?

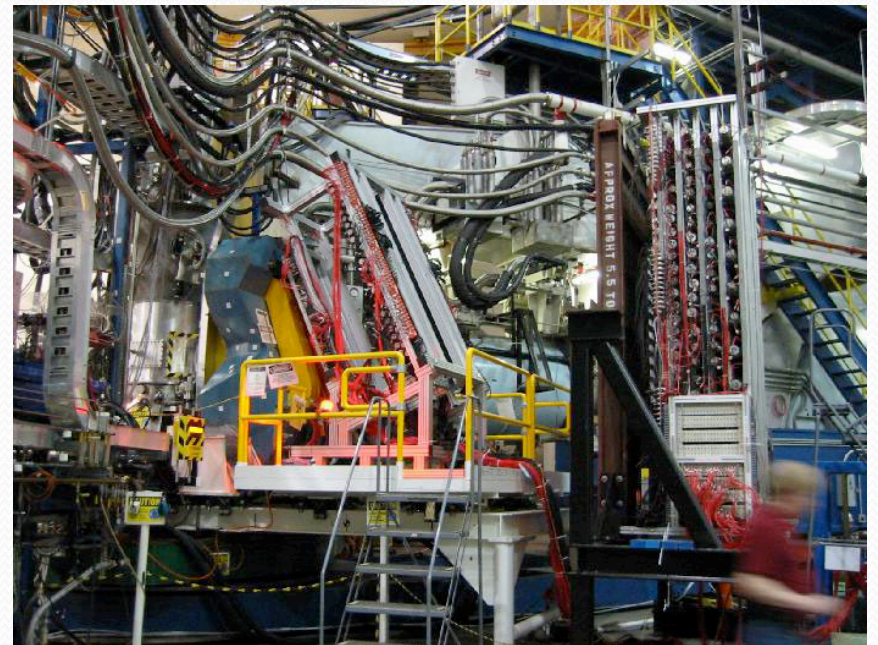
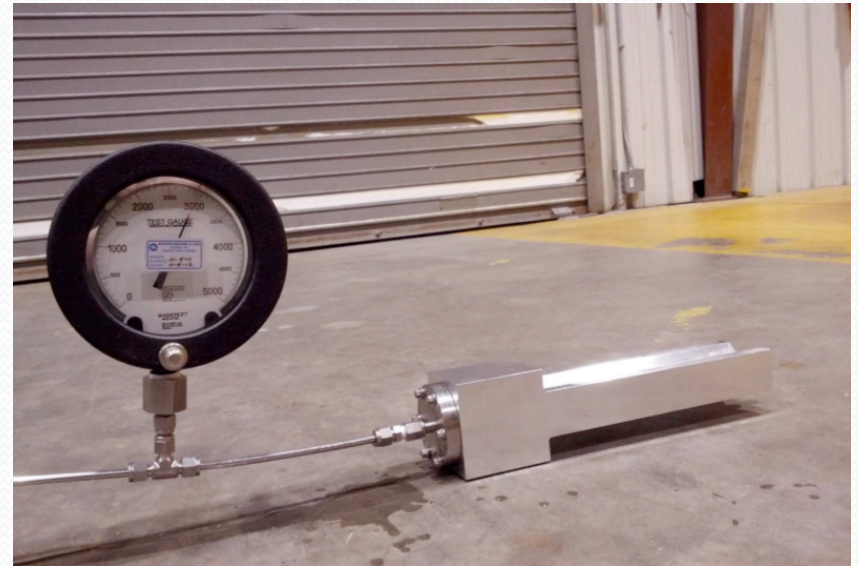

SBS Work in Progress

- DOE approved, project started October 2013
 - Magnet, supports at Jlab
 - Power Supply ordered (may also be used for APEX?)
 - 48D48 should be shipped from BNL within a month
 - Design for stand and motion
 - GEMs
 - Coordinate detector
 - Hadron calorimeter
 - DAQ/tracking/electronics....
- Regular weekly meetings
- Annual review for DOE expected in fall

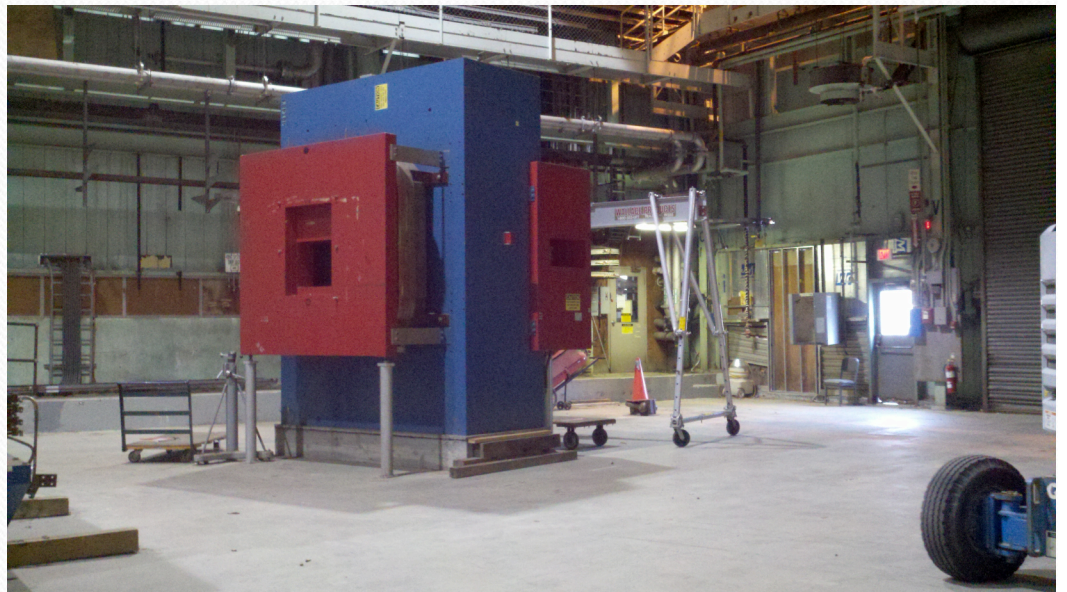
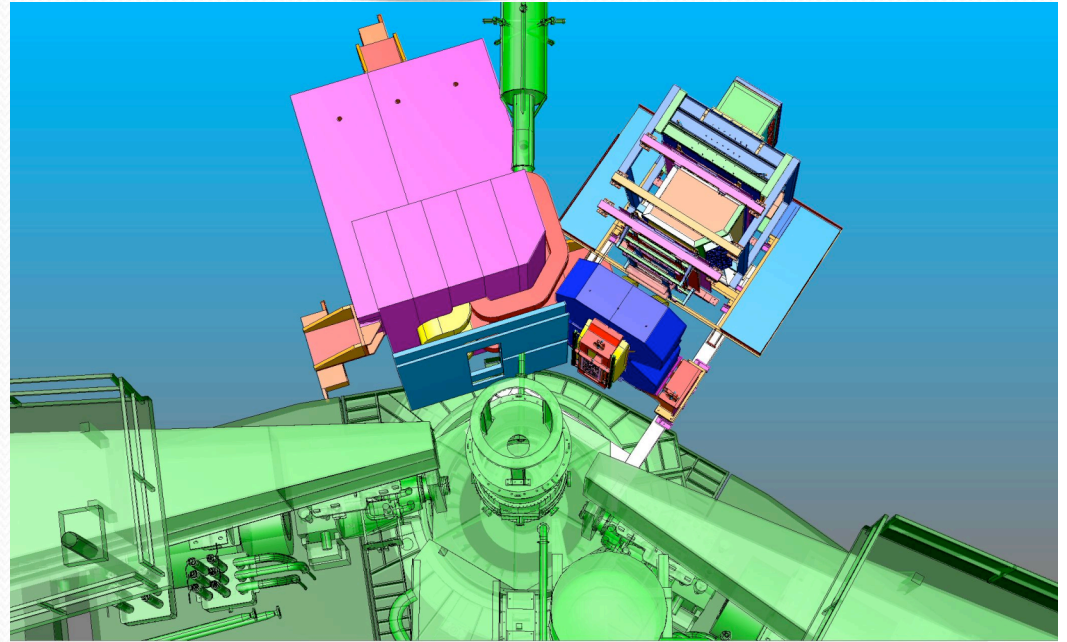

Other Ongoing Efforts

- Polarized ^3He target improvements and development
- APEX - new septum magnet design
- PREX - shielding and polarimetry
- MOLLER - magnet design and polarimetry, fall review?
- SoLID - CLEO magnet request imminent, simulations, Director's review?
- Although likely farther in the future, there's much to do for all of the above now to be ready in time...working in parallel!
- Apologies if I forgot something...



Some final thoughts....

- Hall A will have beam time starting in *less than a year!*
- Many parallel efforts
- There is a lot of work to do and the collaboration is encouraged to take on projects, send students, send postdocs,...
- Exciting times – *12 GeV beam is on the way!*