

**For Scintillation Counting, Fast Time Response
51 mm (2 inch) Diameter, Bialkali Photocathode, 8-stage, Head-on Type**

SPECIFICATIONS

GENERAL

Parameter		Description / Value	Unit
Spectral Response		300 to 650	nm
Wavelength of Maximum Response		420	nm
Window Material		Borosilicate glass	—
Photocathode	Material	Bialkali	—
	Minimum Effective Area	φ46	mm
Dynode	Structure	Linear focused	—
	Number of Stages	8	—
Base		JEDEC No. B20-102 / Flying lead type	—
Operating Ambient Temperature		-30 to +50	°C
Storage Temperature		-80 to +50	°C
Suitable Socket		E678-20B (supplied)	—

MAXIMUM RATINGS (Absolute Maximum Values)

Parameter		Value	Unit
Supply Voltage	Between Anode and Cathode	1750	V
Average Anode Current		0.1	mA

CHARACTERISTICS (at 25 °C)

Parameter		Min.	Typ.	Max.	Unit
Cathode Sensitivity	Luminous (2856 K)	70	95	—	μA/lm
	Blue Sensitivity Index (CS 5-58)	9	11	—	—
Anode Sensitivity	Luminous (2856 K)	10	47.5	—	A/lm
Gain		—	5.0 × 10 ⁵	—	—
Anode Dark Current (After 30 minute storage in darkness)		—	15	100	nA
Time Response	Anode Pulse Rise Time	—	1.8	—	ns
	Electron Transit Time	—	20	—	ns
	Transit Time Spread (FWHM)	—	250	—	ps
Pulse Linearity (±2 % deviation)		—	50	—	mA

NOTE: Anode characteristics are measured with a voltage distribution ratio and supply voltage shown below.

VOLTAGE DISTRIBUTION RATIO AND SUPPLY VOLTAGE

Electrodes	K	G	Dy1	Dy2	Dy3	Dy4	Dy5	Dy6	Dy7 (Acc)	Dy8	P
Ratio	1.3	4.8	1.5	1.5	1	1	1	1	1	1	1

Supply Voltage: 1500 V, K: Cathode, Dy: Dynode, P: Anode, G: Grid,
Acc to be connected to Dy7 with a protection resistor (R11) in series. (See Figure 4)

PHOTOMULTIPLIER TUBE R9779

Figure 1: Typical Spectral Response

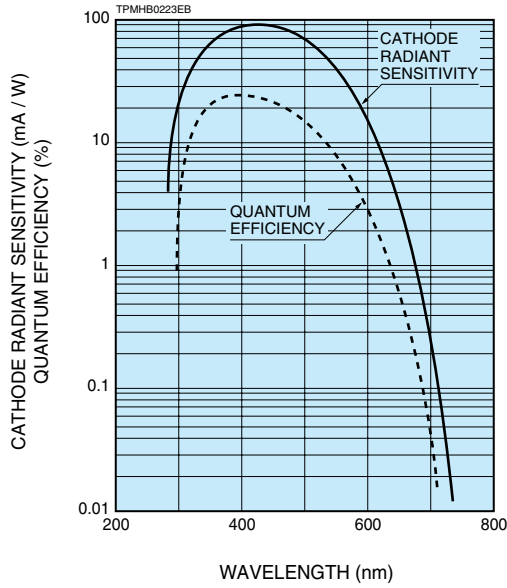

Figure 2: Typical Gain

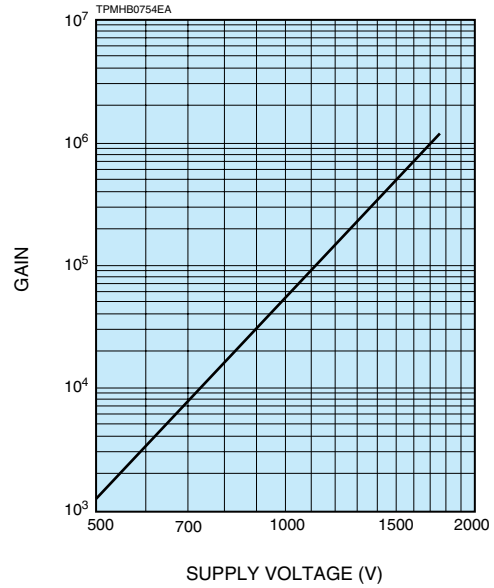
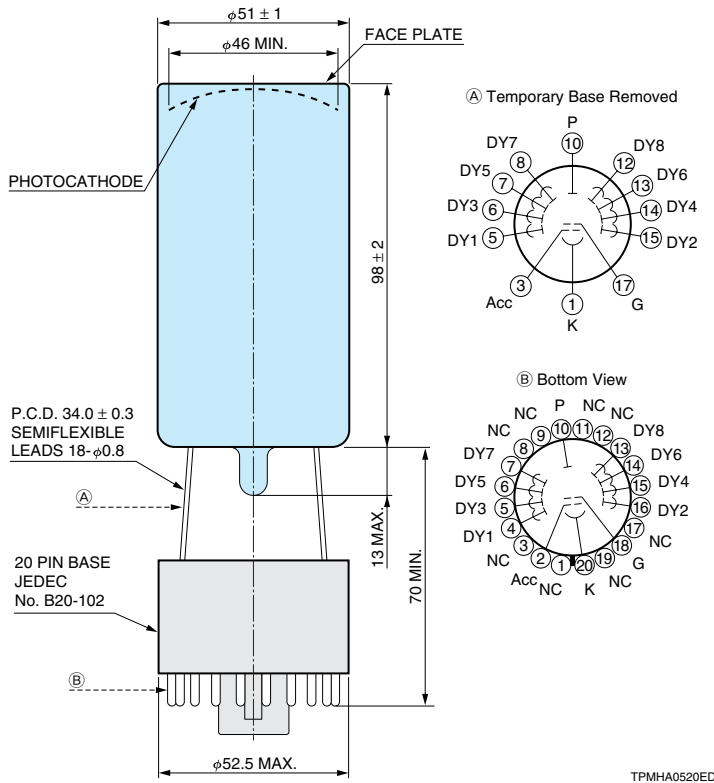
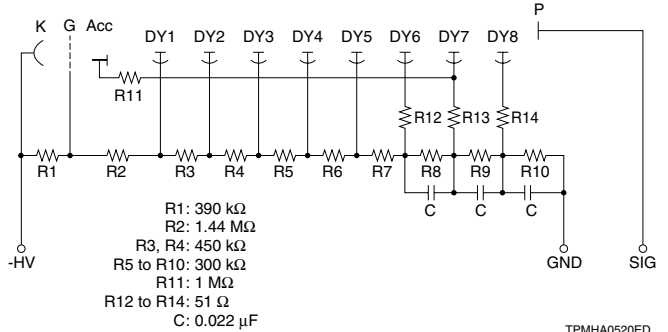

Figure 3: Dimensional Outline and Basing Diagram (Unit: mm)



Recommended Voltage Divider Circuit



Socket E678-20B (Supplied)

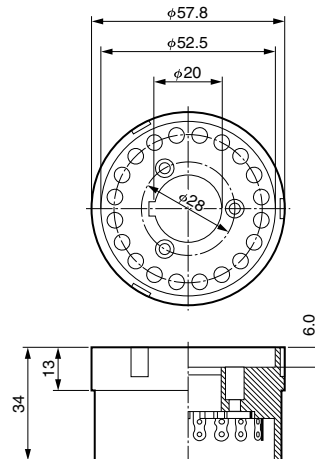

NOTES

The material in the R9779 contains beryllium. Please follow the applicable regulations regarding disposal of hazardous materials and industrial wastes in your country, state, region or province.

HAMAMATSU PHOTONICS K.K. www.hamamatsu.com

HAMAMATSU PHOTONICS K.K., Electron Tube Division

314-5, Shimokanzo, Iwata City, Shizuoka Pref., 438-0193, Japan, Telephone: (81)539/62-5248, Fax: (81)539/62-2205

U.S.A.: Hamamatsu Corporation: 360 Foothill Road, P. O. Box 6910, Bridgewater, N.J. 08807-0910, U.S.A., Telephone: (1)908-231-0960, Fax: (1)908-231-1218 E-mail: usa@hamamatsu.com

Germany: Hamamatsu Photonics Deutschland GmbH: Arzbergerstr. 10, D-82211 Herrsching am Ammersee, Germany, Telephone: (49)8152-375-0, Fax: (49)8152-2658 E-mail: info@hamamatsu.de

France: Hamamatsu Photonics France S.A.R.L.: 19, Rue du Saule Trapu, Parc du Moulin de Massy, 91882 Massy Cedex, France, Telephone: (33)1 69 53 71 00, Fax: (33)1 69 53 71 10 E-mail: infos@hamamatsu.fr

United Kingdom: Hamamatsu Photonics UK Limited: 2 Howard Court, 10 Tewin Road Welwyn Garden City Hertfordshire AL7 1BW, United Kingdom, Telephone: 44-(0)1707-294888, Fax: 44(0)1707-325777 E-mail: info@hamamatsu.co.uk

North Europe: Hamamatsu Photonics Norden AB: Smidesvägen 12, SE-171-41 SOLNA, Sweden, Telephone: (46)8-509-031-00, Fax: (46)8-509-031-01 E-mail: info@hamamatsu.se

Italy: Hamamatsu Photonics Italia: S.R.L.: Strada della Moia, 1/E, 20020 Arese, (Milano), Italy, Telephone: (39)02-935 81 733, Fax: (39)02-935 81 741 E-mail: info@hamamatsu.it

China: HAMAMATSU PHOTONICS (CHINA) Co., Ltd.: 1201 Tower B, Jiaming Center, No.27 Dongshanhuan Bellu, Chaoyang District, Beijing 100020, China, Telephone: (86)10-6586-6006, Fax: (86)10-6586-2866 E-mail: hpc@hamamatsu.com.cn

TPMH1297E06
MAY 2012 IP