



Compton Polarimetry Status

- *Compton Polarimeter Overview.*
- *Recent Results.*
- *Integrating Photon Signal Method.*

H. Benaoum hbenaoum@physics.syr.edu

Syracuse University

Compton Polarimetry

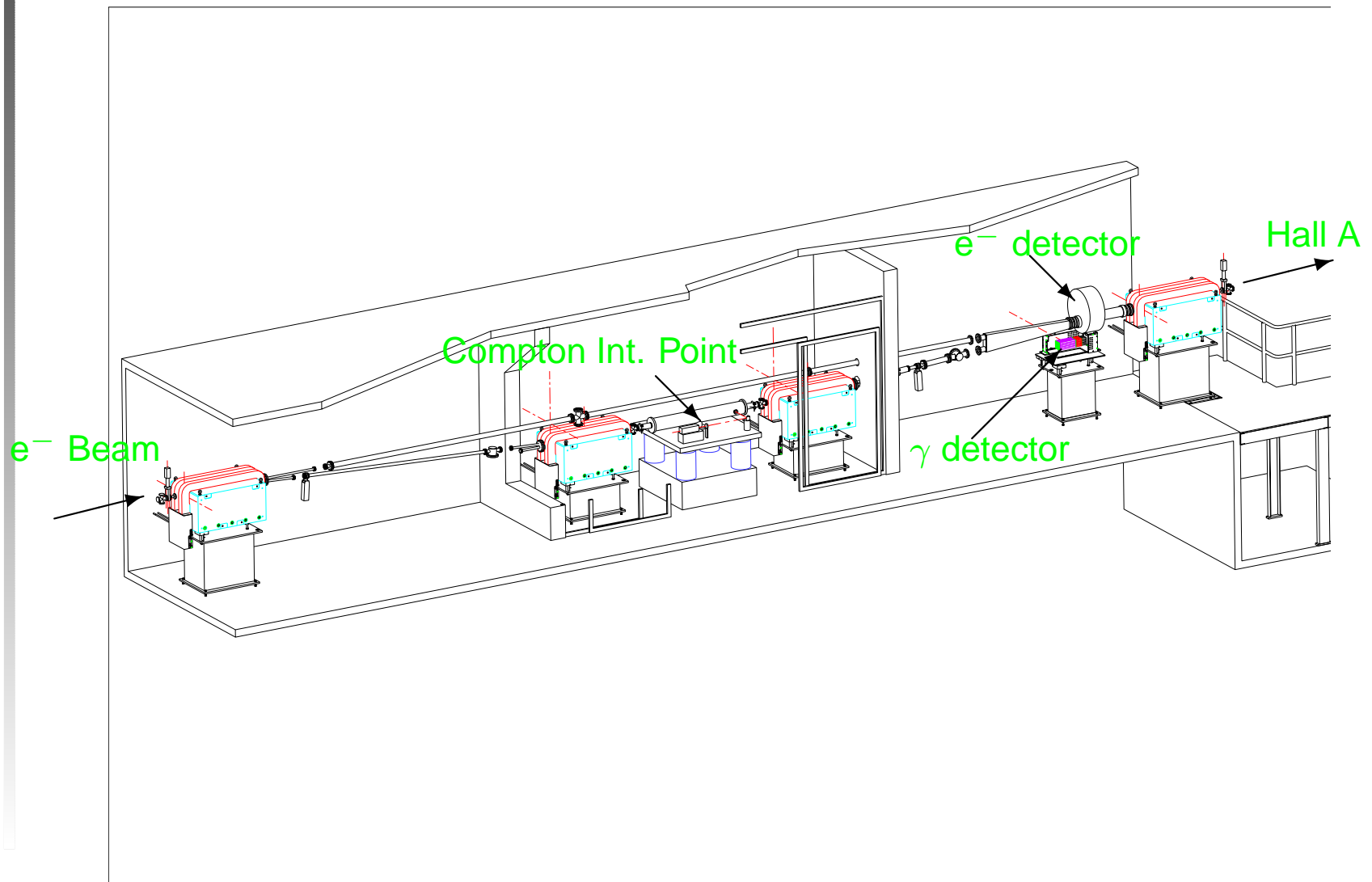

Photon & Electron Spectra

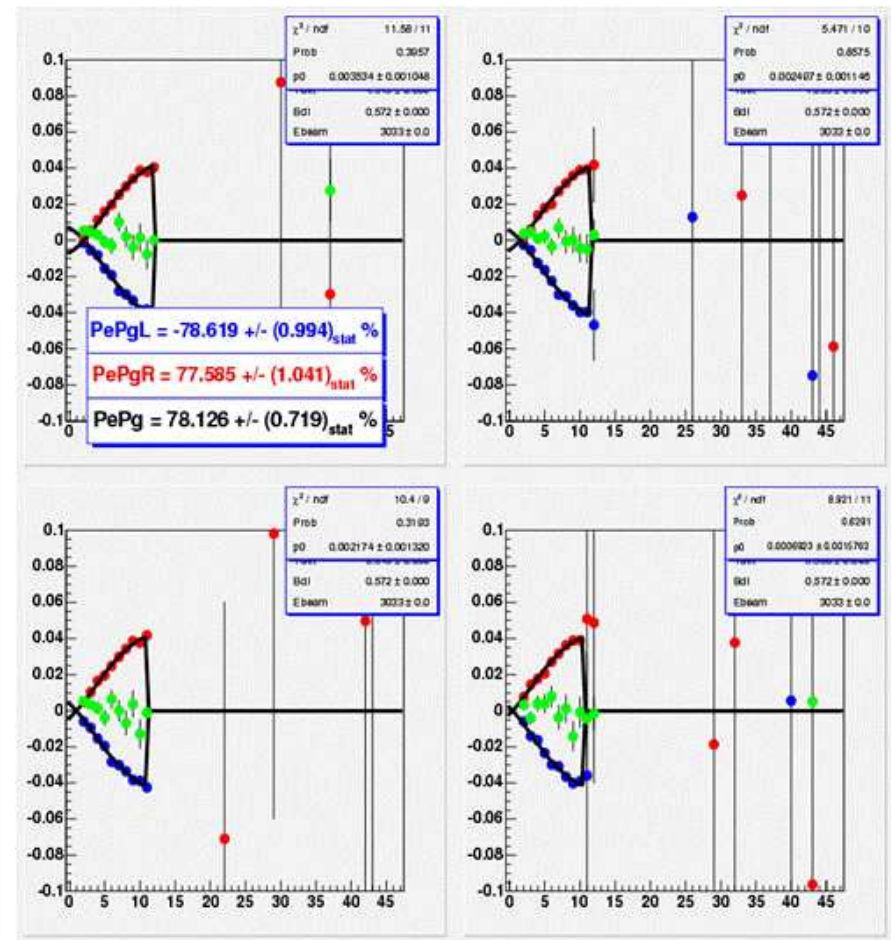
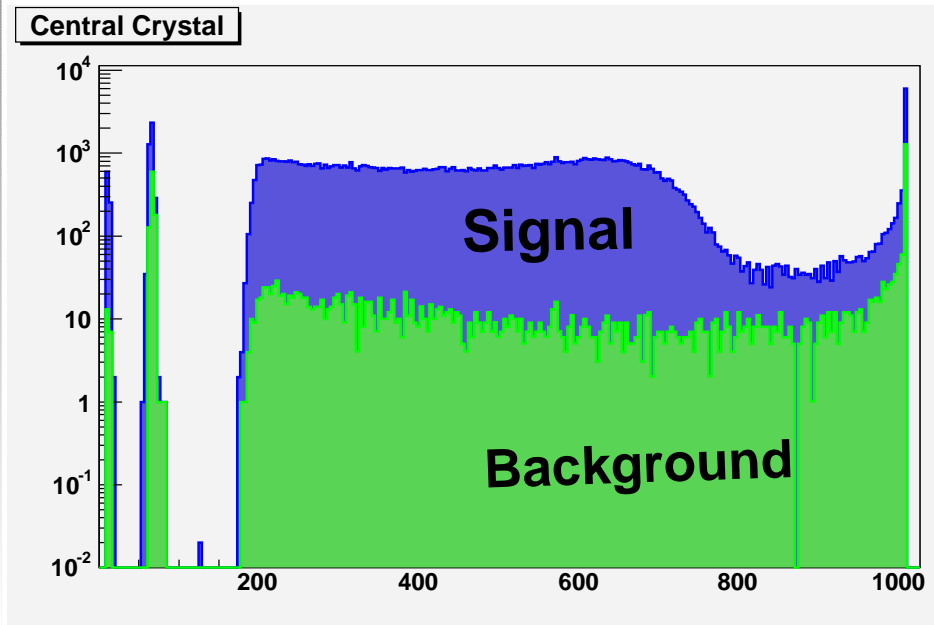

Recent Results : Happex Helium 4

■ Using Gun3 with strained superlattice photocathode .

Beam Polarization - ^4He run

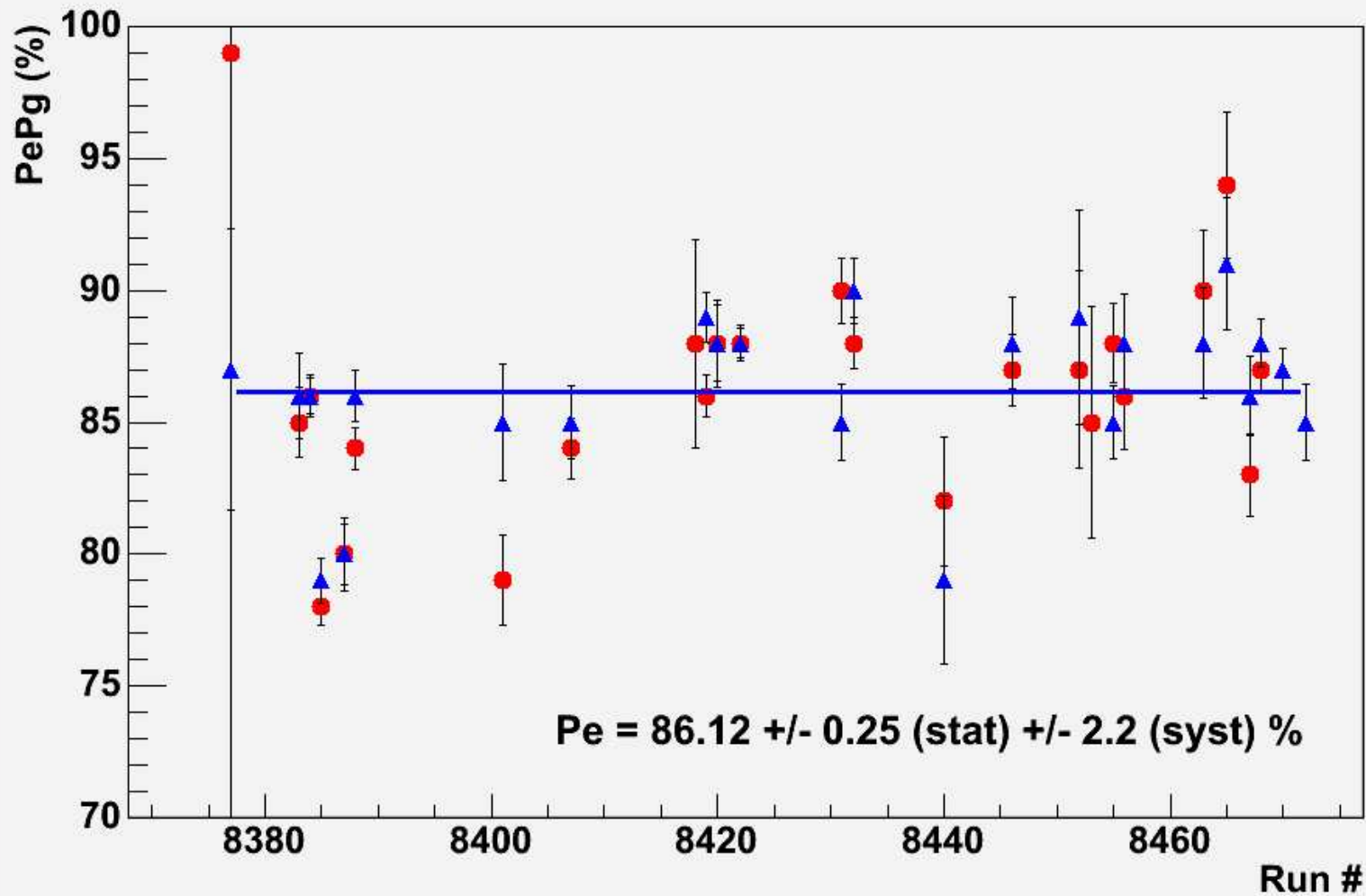

Recent Results : Happex Hydrogen

Beam Polarization - Hydrogene run

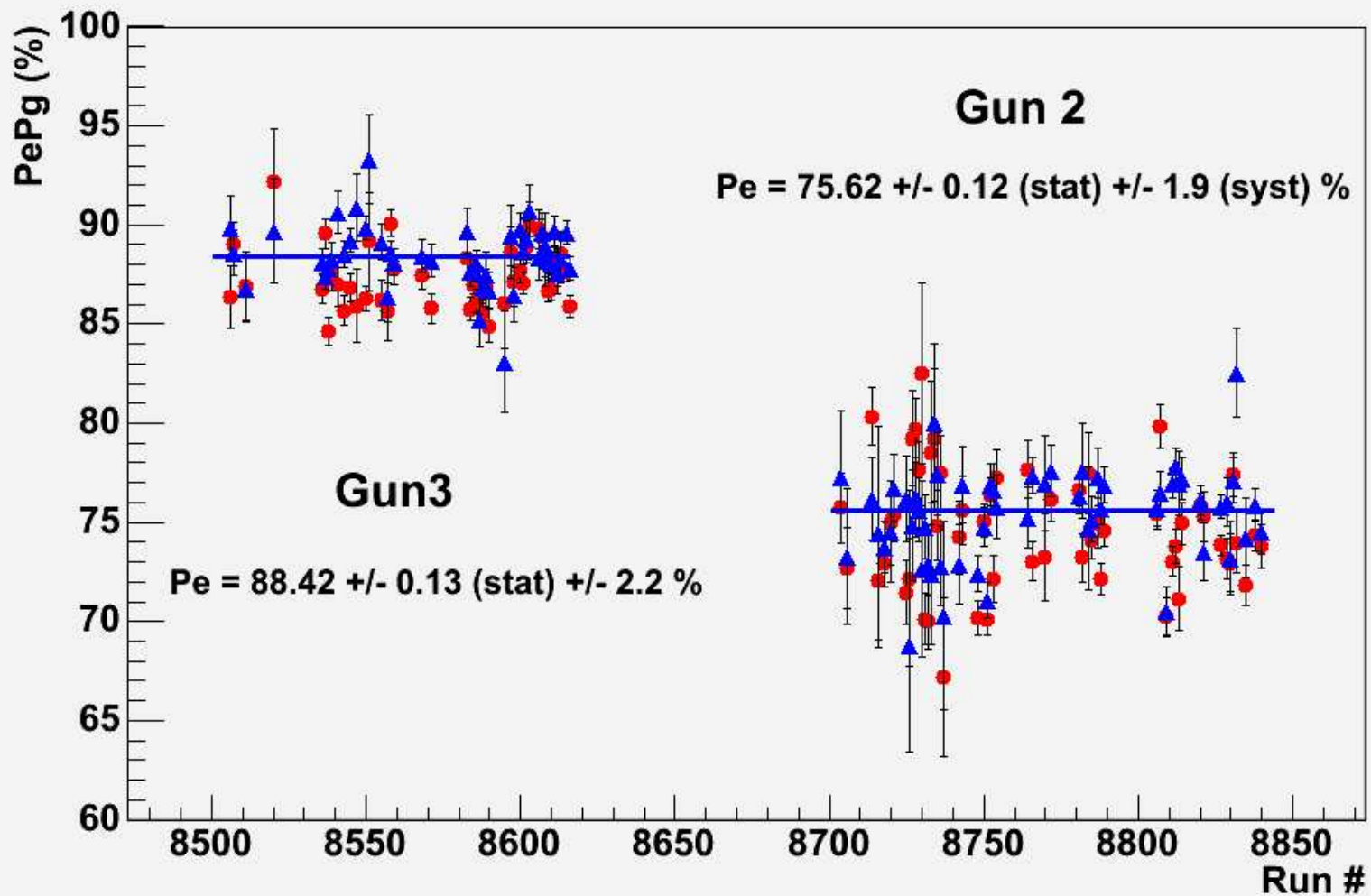

Compton Photon Analysis

Error Budget :

	Happex run	Next Year	Integrating Method
P_γ	1.50%	1.00%	1.00%
Response function	1.25%	1.25%	No
Dead time	1.00%	0.50%	No
Pile up	1.00%	0.50%	No if linear
Radiative Corr.	0.25%	0.25%	0.25%
Bgr. Subtraction			0.50%
Total	2.50%	1.80%	~ 1.00%

Integrating Compton Photon Signal

1. **Differential (or Counting) Method** : scattered photon or electron energy measured each **event** which introduced **systematics errors** related to the details of the detectors and electronics **response function** .

2. **Integrating Method** : integrate over energy range the total compton signal for each helicity state.

■ **Motivation** : **reduces** the above **systematics** to roughly **1 %** by getting rid of response function and dead time systematics .

■ **Setup** :

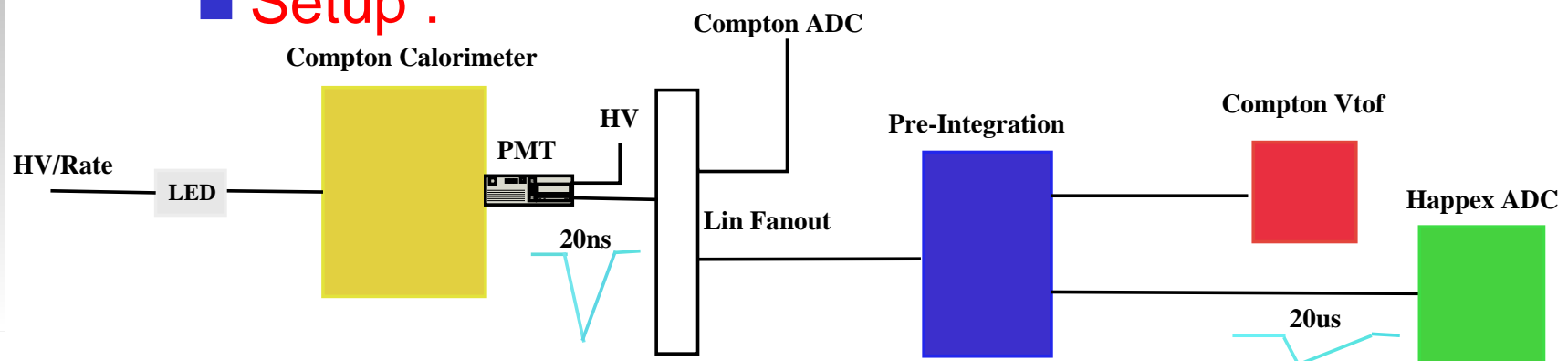

Int. Signal Happex vs. Compton DAQ

- Integrated Compton signal, Compton Cavity Lock (ON, OFF) and Compton Laser Polarisation cables are connected to Happex DAQ .
- **Linearity** : done some tests and still working on that .

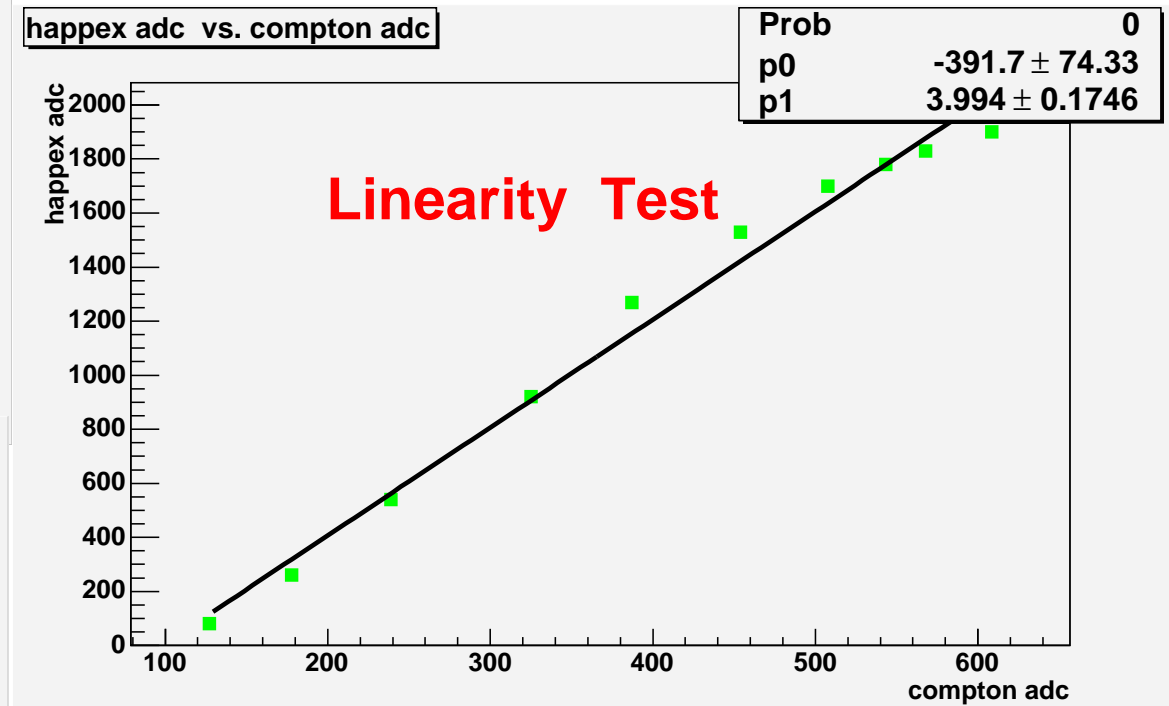
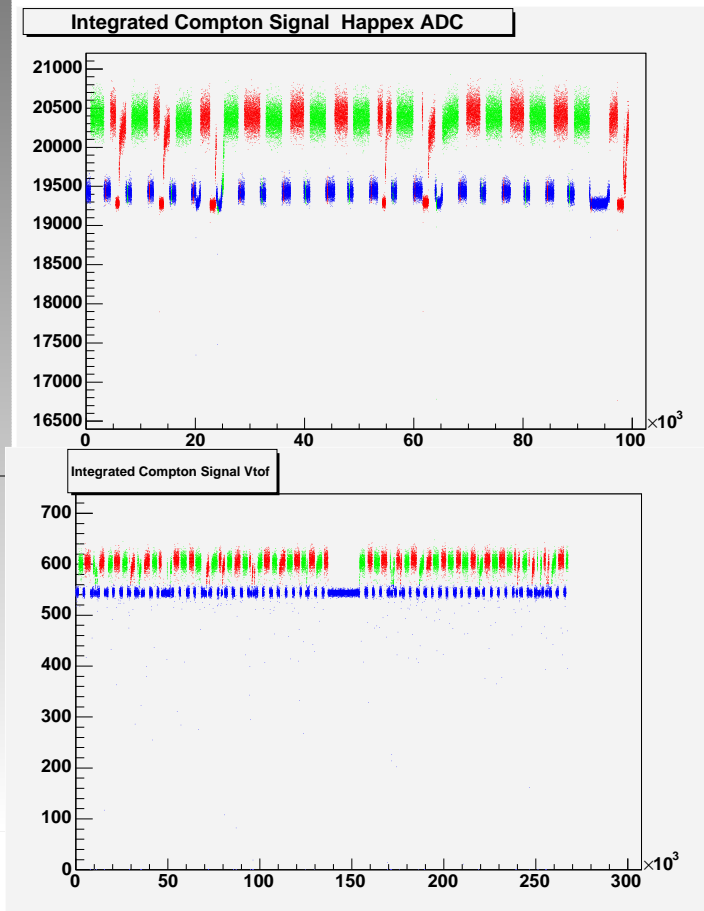

High Background Example

- Bad run where no clear separation between Signal and Bgr.
- $S/N = 0.8$

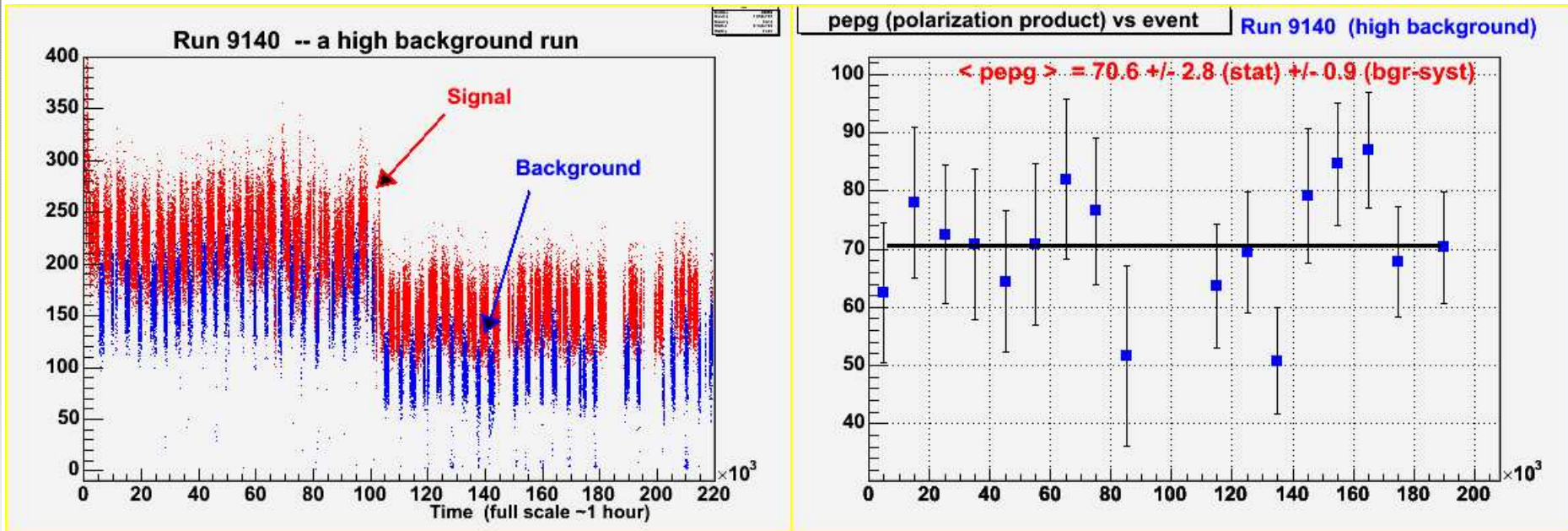

Comparing integrating to counting Method

