



APPLICATION NOTE 3250

Characterizing the S-Parameters of 75Ω Circuits using 50Ω Lab Equipment

Abstract: RF engineers working with cable, terrestrial, or satellite TV applications are frequently required to make S-parameter measurements. Using a minimum loss pad to transform the conventional 50Ω test port impedance to the 75Ω device provides a cheap, easy way to get reasonable measurements.

For most general lab applications below 1GHz, a PCB-mounted minimum loss pad built from 1% 0402 or similar resistors offers a quick and easy means to test a 75Ω circuit with 50Ω lab equipment. In most cases, the only correction factor required is the insertion loss of the MLP – 5.7dB plus any addition connectors. Difficult calculations or even Smith Chart work is often not required to make basic S-Parameter measurements.

RF engineers working with cable, terrestrial, or satellite TV applications are frequently required to make S-Parameter measurements on these circuits. The first time the uninitiated engineer uses a Vector Network Analyzer to verify that a TV tuner input offers the return loss they expect, the problem becomes obvious: How do I measure [S]-parameters of my 75Ω DUT on a 50Ω VNA? If the situation warrants the cost, the answer is to buy lab equipment designed specifically for measuring 75Ω circuits (75Ω source and load impedance test ports). Otherwise, using a minimum loss pad to transform the conventional 50Ω test port impedance to the 75Ω DUT provides a cheap, easy way to get reasonable measurements.

When an IC manufacturer specifies the input return loss ($|S_{11}|$) of new cable TV LNA, the measurement is necessarily referred to 75Ω. That is to say, if $|S_{11}| = -30\text{dB}$ (reflected power is only one part in a thousand - essentially a perfect match), the idea is that when driven with a 75Ω source impedance, the device input will allow virtually all of the power to be transferred to the LNA.

The same tuner input will NOT offer good return loss when driven from a 50Ω source impedance. Directly connecting this perfectly-matched tuner input to a 50Ω VNA will yield an $|S_{11}|$ measurement something close to -14dB - with reflected power now one part in 25! So with this same 50Ω VNA, how can we verify that the TV tuner input is as good as we say it is?

A matching circuit is required; it should have flat frequency response and the lowest insertion loss possible. The industry-standard answer to this is the "minimum loss pad" (often seen "MLP") -- the simple resistive network of **Figure 1**. The key feature of this network is that it transforms a 75Ω DUT load impedance into 50Ω for the measurement instrument, and transforms the 50Ω source impedance of the instrument to the native 75Ω impedance of the DUT. In this way, reflections are removed, the response is flat, and the loss of the network is easily backed out of the measurement to get to the DUT. These "minimum loss pads" are widely available from test equipment vendors, and the network can be constructed very quickly on the bench when needed.

The term "minimum loss" refers to the fact that this network offers the lowest insertion loss of the possible configurations of resistive networks that offer the same transformation.

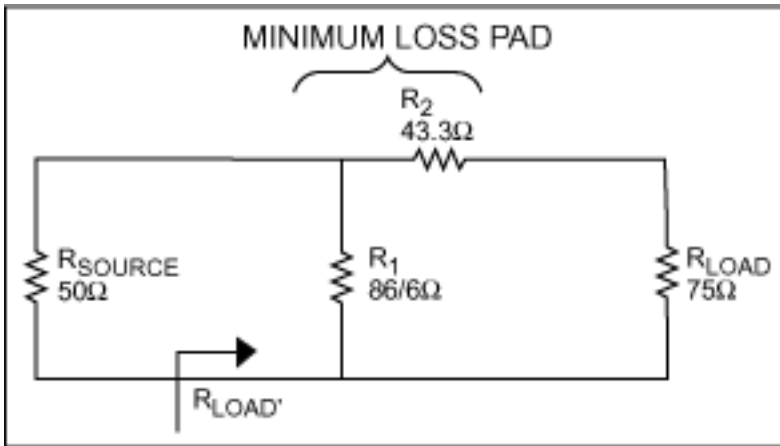

Figure 1. Minimum Loss Pad used to match a 75Ω DUT to a 50Ω test port. Insertion loss is 5.72dB at low frequency. Upper limit of frequency response flatness is determined by quality of construction.

The math required to transform Z_{LOAD} into Z_{LOAD}' is straight-forward, and is offered in Appendix A. The resulting expression for Z_{LOAD}' describes the cascaded impedance of the MLP and the DUT, as seen from the measurement port (R_{SOURCE}). Turning the equation around and solving for Z_{LOAD} in terms of Z_{LOAD}' offers a way to back out the affects of the MLP, and determine the true Z_{LOAD} from the measurement data taken at Z_{LOAD}' . This quick algebra work is in Appendix B for reference, but the result is provided here:

$$Z_{LOAD} = \frac{Z_{LOAD}'(R_1 + R_2) - R_1 R_2}{R_2 - Z_{LOAD}'}$$

A sanity-check calculation proves sound. Assume we just made an impedance measurement of a 75Ω resistor through the MLP. The assumption is that the VNA will measure $R_{LOAD}' = 50\Omega$ (infinite return loss), and we expect the math to tell us that this result came from a load resistor of 75Ω. Let $R_{LOAD}' = 50\Omega$, and we see that with $R_1 = 43.3\Omega$ and $R_2 = 86.6\Omega$, we get $Z_{LOAD} = 75\Omega$ as expected.

This simple expression could be made more useful by breaking up the Real and Imaginary components, and using a spreadsheet to do the calculations on the bench.

Generally, the target measurements of the 75Ω DUT will be more diverse than just an impedance measurement - return loss in dB, gain and reverse isolation, noise figure and input third-order intercept are all common. In cases like these, it is helpful to make a few general statements about the MLP:

- (1) As long as R_{LOAD} is near 75Ω, additional VSWR caused by the mismatch caused by the MLP is minimized, and it is safe to assume that the MLP is adding negligible measurement uncertainty due to mismatch.
- (2) Conversely, as R_{LOAD} diverges from 75Ω, the MLP is no longer doing the correct impedance transformation, and this added VSWR between the measurement port and the MLP, and the MLP and the DUT, causes additional measurement uncertainty. There are many tools to relate mismatch (often in terms of VSWR) to measurement uncertainty.
- (3) The MLP can be considered purely resistive over the frequency range for which it is specified. It offers 5.7dB insertion loss, plus the loss in the additional connectors and cabling.
- (4) Out-and-back path loss in an S11 or S22 measurement, and through loss in an S21 or S12 measurement, is twice the insertion loss (at least 11.4dB) - this reduces the effective sensitivity and dynamic range of the VNA by this amount.

In a practical example, let's say we want to measure S21 of a cable/terrestrial TV LNA like Maxim's MAX3558 Quad LNA. The DUT is inserted in the test setup with MLPs at both the input and output, as in **Figure 2**. Calibrate the VNA as usual, not including the MLPs in the cal. Connect port 1 to the 50Ω side of one MLP, and connect the 75Ω side to the LNA input. Do the same for one of the outputs and port 2 on the VNA.

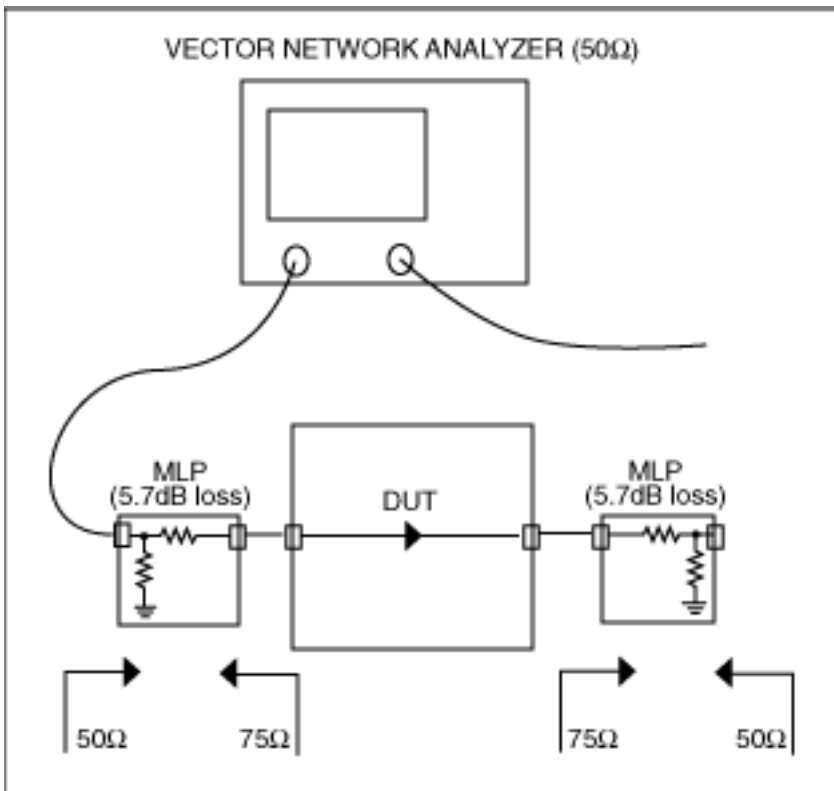

Figure 2. Testing MAX3558 Quad Cable/Terrestrial LNA with a 50Ω

VNA, using two minimum loss pads for impedance transformation. Make the S21 (forward gain) measurement. The VNA will indicate a gain at 500MHz near -5dB. Simply back out the 11.5 or 12.0dB insertion loss from the two MLPs and their connectors/adapters, and we see the LNA is providing a 75Ω power gain of about 7dB.

The S12 (reverse isolation) measurement is not as straight-forward. The isolation spec on these LNAs is 65dB. Accounting for the additional loss of the two MLPs, and the VNA itself needs to resolve an S12 of 77dB. If we're not careful, the received port power will be too low for the VNA to accurately measure it. The goal should be to keep the received port power (port 1) at least 10dB above the VNA's noise/internal isolation floor -- without an isolation calibration, this is roughly -100dBm. Therefore, we need to set the source port power to at least -20dBm, preferably -10dBm or even 0dBm. With adequate received power at port 1, make the measurement, and back out the insertion loss from the measurement by adding 12dB to the measured value. That is, -77dB measured becomes -65dB at the DUT.

The MAX3558 Evaluation Kit has pads allow the engineer to insert their own minimum loss pad right on the PCB. The 75Ω F-type connector should be replaced with a 50Ω SMA or similar.

At frequencies above several hundred MHz, a PCB-mounted MLP built from 0402 resistors brings measurement accuracy into question. Parasitic affects break the assumption that this network is purely resistive - cases like this require a more complicated approach to the problem altogether. One method would be to fully characterize the MLP, and use a Smith Chart to more accurately back out the effects of the matching circuit. Another solution is to use an inductor-based transformer to do the impedance transformation with much lower loss. RF transformers are usually described in terms of their impedance transformation ratio, not the turns ratio, so find one described as "1.5:1."

For most general lab applications below 1GHz, a PCB-mounted minimum loss pad built from 1% 0402 or similar resistors offers a quick and easy means to test a 75Ω circuit with 50Ω lab equipment. In most cases, the only correction factor required is the insertion loss of the MLP - 5.7dB plus any addition connectors. Difficult calculations or even Smith Chart work is often not required to make basic S-Parameter measurements. High-quality production-tested MLPs are available from lab equipment vendors when better accuracy, or a higher frequency range, is required.

Appendix A: Derive $Z_{LOAD'}$ in terms of Z_{LOAD}

$$Z_{LOAD'} = (Z_{LOAD} + R_1) \parallel R_2$$

$$Z_{LOAD'} = \frac{(Z_{LOAD} + R_1)R_2}{(Z_{LOAD} + R_1) + R_2}$$

$$Z_{LOAD'} = \frac{Z_{LOAD}R_1 + R_2R_1}{Z_{LOAD} + R_1 + R_2}$$

Appendix B: Derive Z_{LOAD} in terms of $Z_{LOAD'}$

$$Z_{LOAD'} = \frac{Z_{LOAD}R_1 + R_1R_2}{Z_{LOAD} + R_1 + R_2}$$

$$(Z_{LOAD'})(Z_{LOAD}) + (Z_{LOAD'})(R_1) + (Z_{LOAD'})(R_2) = Z_{LOAD}R_1 + R_1R_2$$

$$(Z_{LOAD'})(Z_{LOAD}) - (Z_{LOAD})(R_1) = R_1R_2 - (Z_{LOAD'})(R_1) - (Z_{LOAD'})(R_2)$$

$$(Z_{LOAD}) = \frac{R_1R_2 - (Z_{LOAD'})(R_1 + R_2)}{(Z_{LOAD'} - R_1)}$$

$$(Z_{LOAD}) = \frac{(Z_{LOAD'})(R_1 + R_2) - R_1R_2}{(R_1 - Z_{LOAD'})}$$

A similar article appeared in the April 2004 issue of *RF Design*.

Application Note 3250: <http://www.maxim-ic.com/an3250>

More Information

For technical questions and support: <http://www.maxim-ic.com/support>

For samples: <http://www.maxim-ic.com/samples>

Other questions and comments: <http://www.maxim-ic.com/contact>

Related Parts

MAX3558: [QuickView](#) -- [Full \(PDF\) Data Sheet](#)

AN3250, AN 3250, APP3250, Appnote3250, Appnote 3250

Copyright © by Maxim Integrated Products

Additional legal notices: <http://www.maxim-ic.com/legal>