

Next Steps

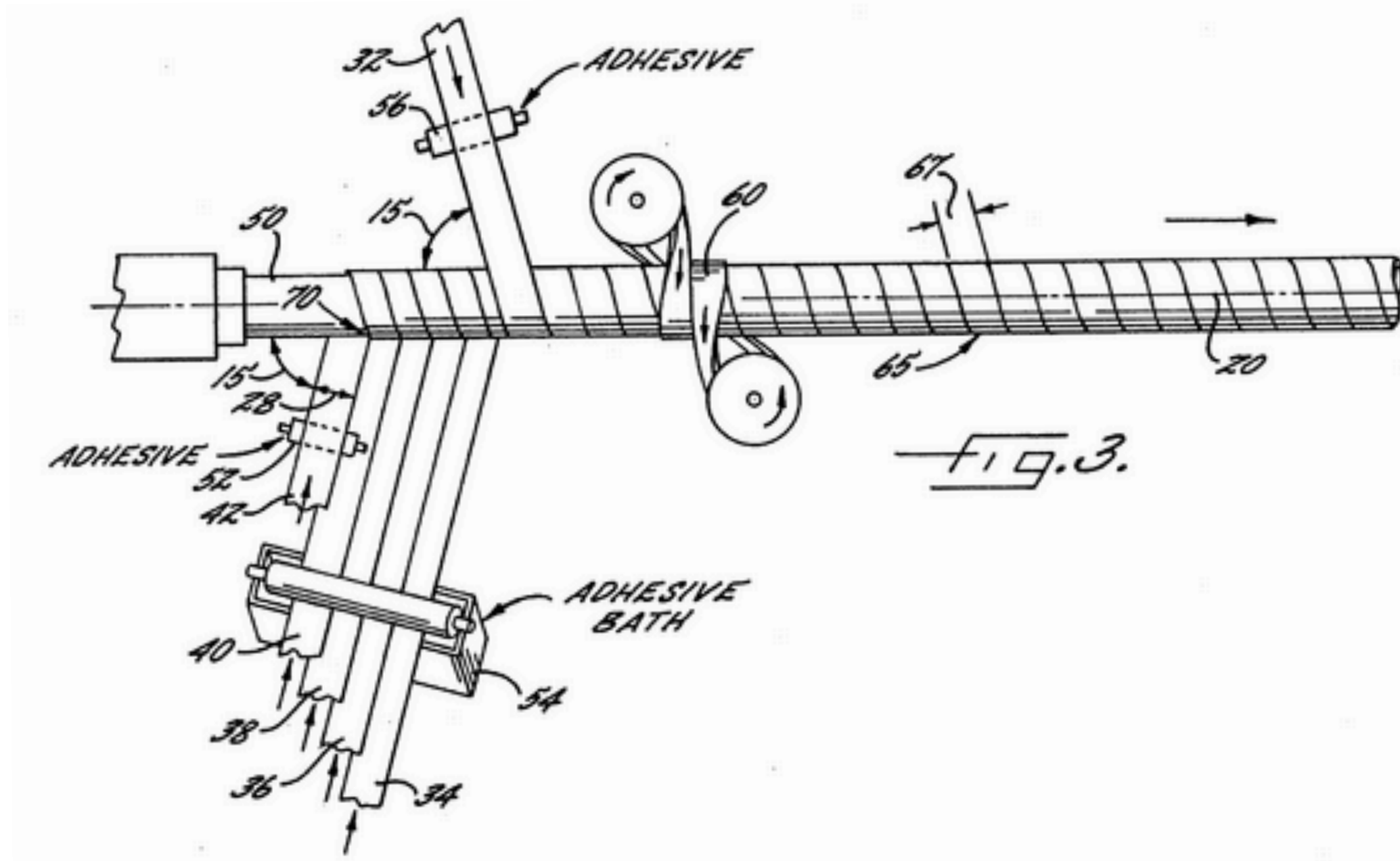

1. Obtain spiral-wound 25 um tubes.
2. Glue on aluminum tubes and flanges to the end of the straw tubes.
3. Pressure testing and ballooning to be tested.
4. If successful the tube thickness and uniformity will be measured using a Hall probe based thickness measurement device at JLab (target group has such as device).

