

Hardware Installation Guide

Revision n.2
3 December 2002

MOD. SY 1527
UNIVERSAL MULTICHANNEL
POWER SUPPLY SYSTEM
HARDWARE INSTALLATION
GUIDE

NPO:
00103/97:1527x.MUTx/02

CAEN will repair or replace any product within the guarantee period if the Guarantor declares that the product is defective due to workmanship or materials and has not been caused by mishandling, negligence on behalf of the User, accident or any abnormal conditions or operations.

CAEN declines all responsibility for damages or injuries caused by an improper use of the Modules due to negligence on behalf of the User. It is strongly recommended to read thoroughly the CAEN User's Manual before any kind of operation.



CAEN reserves the right to change partially or entirely the contents of this Manual at any time and without giving any notice.

TABLE OF CONTENTS

1. ABOUT THIS GUIDE	6
1.1 ORGANISATION.....	7
1.2 CONVENTIONS	8
1.2.1 <i>Safety rules</i>	8
1.2.2 <i>Electrical signal specifications</i>	8
2. GENERAL DESCRIPTION OF THE SYSTEM.....	9
2.1 OVERVIEW.....	9
2.2 SHORT FUNCTIONAL DESCRIPTION.....	11
2.3 TECHNICAL SPECIFICATION TABLE.....	14
3. DESCRIPTION OF THE MECHANICAL PARTS	18
3.1 THE SY1527 MAINFRAME AND ITS MECHANICAL PARTS.....	18
3.2 BOARD SECTION	20
3.2.1 <i>Board Backplane</i>	20
3.2.2 <i>High and Low Voltage, Floating and Miscellaneous boards</i>	20
3.2.3 <i>Distributors</i>	20
3.2.4 <i>Branch Controllers</i>	20
3.3 FAN TRAY SECTION.....	20
3.4 POWER SUPPLY SECTION.....	22
3.4.1 <i>Power Supply Backplane</i>	23
3.4.2 <i>Primary Power Supply (Mod. A 1531)</i>	23
3.4.3 <i>Power Supply Units (Mod. A1532)</i>	25
3.5 CPU SECTION	27
3.5.1 <i>Interface bus backplane</i>	29
3.5.2 <i>CPU board</i>	29
3.5.3 <i>Interface board</i>	29
3.5.4 <i>Additional interface boards</i>	29
3.6 FRONT PANEL	30
3.6.1 <i>LCD screen, keypad and compact switch</i>	31
3.6.2 <i>Interface Bus Section</i>	31
3.6.3 <i>I/O Control Section</i>	32
3.7 REAR PANEL.....	35
4. TECHNICAL SPECIFICATIONS	36
4.1 PACKAGING	36
4.2 POWER REQUIREMENTS	36
4.3 EXTERNAL CONNECTORS, DISPLAYS AND SWITCHES	36
4.3.1 <i>INPUTS</i>	36
4.3.2 <i>OUTPUTS</i>	37
4.3.3 <i>I/O CONNECTORS</i>	38
4.3.3.1 <i>I/O control section</i>	38

4.3.3.2	Interface bus section.....	39
4.3.4	<i>DISPLAYS</i>	40
4.3.5	<i>SWITCHES</i>	41
4.3.6	<i>BUTTONS</i>	42
4.4	EXTERNAL CONNECTORS, DISPLAYS AND SWITCHES OF THE PRIMARY POWER SUPPLY	43
4.4.1	<i>INPUTS</i>	43
4.4.2	<i>OUTPUTS</i>	43
4.4.3	<i>DISPLAYS</i>	43
4.4.4	<i>SWITCHES</i>	44
4.5	EXTERNAL DISPLAYS OF THE POWER SUPPLY UNITS.....	44
4.5.1	<i>DISPLAYS</i>	44
4.6	EXTERNAL CONNECTORS AND SWITCHES OF THE REAR PANEL	44
4.6.1	<i>INPUTS</i>	44
4.6.2	<i>SWITCHES</i>	45
5.	UNPACKING THE SYSTEM.....	46
5.1	CHECK LIST.....	46
6.	SAFETY INFORMATION AND INSTALLATION REQUIREMENTS	47
6.1	GENERAL SAFETY INFORMATION.....	47
6.1.1	<i>Injury Precautions</i>	47
6.1.2	<i>Product Damage Precautions</i>	48
6.1.3	<i>EC Certifications and Compliances</i>	48
6.2	TERMS IN THIS MANUAL	48
6.3	TERMS AND SYMBOLS ON THE PRODUCT	49
6.4	INSTALLATION REQUIREMENTS	49
6.4.1	<i>Standalone operation</i>	49
6.4.2	<i>Remote operation via terminal</i>	49
7.	HARDWARE INSTALLATION AND SET-UP.....	50
7.1	INSTALLATION	50
7.1.1	<i>Installing the primary power supply and the power supply units</i>	50
7.1.2	<i>Installing the boards</i>	52
7.1.3	<i>Connecting the system to the mains</i>	53
7.2	HARDWARE SETTINGS.....	53
7.3	OPERATING MODES AND RELEVANT HARDWARE SET-UPS	54
7.3.1	<i>Standalone operation</i>	54
7.3.2	<i>Remote operation via Terminal</i>	55
7.3.3	<i>Remote Operation via Web Browser</i>	56
7.3.4	<i>Remote operation via Host Computer</i>	56
7.4	CABLING.....	56
7.4.1	<i>Standalone operation</i>	56
7.4.2	<i>Remote operation via terminal</i>	57
7.4.2.1	Using the RS232 interface.....	57
7.4.2.2	Using H.S. CAENET (<i>Multicrate Operation</i>).....	59
7.4.2.3	Using TCP/IP Protocol (<i>Telnet connection</i>).....	59

7.4.3	Remote operation via Web Browser.....	59
7.4.4	Remote operation via host computer	59
7.5	GROUNDING.....	59
8.	SYSTEM POWER-ON	60
8.1	PRELIMINARY CHECK.....	60
8.2	LOCAL POWER-ON	60
8.3	REMOTE POWER-ON.....	61
APPENDIX A.....		62
	SY1527 SYSTEM FRONT PANEL	63

LIST OF FIGURES

FIG. 2.1 – LAYOUT OF THE MAIN MECHANICAL SECTIONS OF THE SY1527 MAINFRAME	9
FIG. 2.2 – BLOCK DIAGRAM OF THE FUNCTIONAL PARTS OF THE SY1527 SYSTEM.....	13
FIG. 3.1 – DETAILS OF THE MECHANICAL PARTS CONTAINED IN THE SY1527 MAINFRAME	19
FIG. 3.2 –AIR FLOW FROM THE FAN TRAY UNIT INTO THE BOARD SECTION	22
FIG. 3.3 – FRONT PANEL OF THE PRIMARY POWER SUPPLY (MOD. A1531).....	24
FIG. 3.4 – FRONT PANEL OF THE POWER SUPPLY UNIT (MOD. A1532)	26
FIG. 3.5 – FRONT PANEL OF THE SY1527 SYSTEM.....	30
FIG. 3.6 – REAR PANEL OF THE SY1527 SYSTEM.....	35
FIG. 4.1 – TRIP IN/OUT PIN ASSIGNMENT	38
FIG. 4.2 – RS232 PIN ASSIGNMENT	39
FIG. 7.1 – STANDALONE OPERATION.....	54
FIG. 7.2 – REMOTE OPERATION VIA TERMINAL.....	55
FIG. 7.3 – LOCATION OF RS232 INTERFACE, VGA PORT, PS/2 CONNECTOR AND ETHERNET INTERFACE.....	57
FIG. 7.4 – ELECTRO-MECHANICAL SPECIFICATIONS OF THE RS232 CABLE (9-PIN TO 9-PIN).....	58
FIG. 7.5 – ELECTRO-MECHANICAL SPECIFICATIONS OF THE RS232 CABLE (9-PIN TO 25-PIN).....	58

LIST OF TABLES

TABLE 2.1 - TECHNICAL SPECIFICATIONS OF THE SY1527 MAINFRAME: GENERAL	14
TABLE 2.2 - TECHNICAL SPECIFICATIONS OF THE SY1527 MAINFRAME: FRONT AND REAR PANEL COMPONENTS	15
TABLE 2.3 - TECHNICAL SPECIFICATIONS OF THE SY1527 MAINFRAME: INPUT AND OUTPUT SIGNALS.....	16
TABLE 3.1 – MECHANICAL AND ELECTRICAL FEATURES OF THE A1531 PRIMARY POWER SUPPLY	25
TABLE 3.2 – MECHANICAL AND ELECTRICAL FEATURES OF THE A1532 POWER SUPPLY UNIT	27
TABLE 4.1 – RS232 PORT DEFAULT SETTINGS	40
TABLE 5.1 – CHECK LIST OF THE PARTS NEEDED FOR SYSTEM INSTALLATION	46

1. About this guide

The purpose of this guide is to illustrate:

- the mechanical and electrical features of the SY1527 Universal Multichannel Power Supply System,
- the requirements and instructions for its correct installation and first power-ON.

The preliminary section of this guide starts with a short description of the SY1527 system and a summary of its main features and performances.

The core of the guide consists of a reference section with a detailed description of the system's mechanical and electrical specifications, the installation requirements and instructions.

A detailed description of system parameters, control commands and operating modes can be found in the *User's Manual*.

1.1 Organisation

This guide is organised as follows:

Chapter 1 – About this guide: it briefly describes this guide's objectives and organisation;

Chapter 2 – General description of the system: it contains an overview of the system and its main features, a very brief functional description and some reference tables with a summary of the system technical specifications;

Chapter 3 – Description of the mechanical parts: it offers a detailed description of the system's mechanical; in particular, the last two sections are devoted to the description of the front and rear panels, including displays and external connectors;

Chapter 4 – Technical specifications: this reference section contains all the system's technical data about the system, such as mainframe mechanics, power requirements, external connections and interfaces and a chapter devoted to system tests and performances;

Chapter 5 – Unpacking the system: it consists of some notes regarding unpacking the system and a useful check list of all parts needed for installation;

Chapter 6 – Safety information and installation requirements: it contains general safety rules and the requirements for a correct system installation;

Chapter 7 – Hardware installation and set-up: it contains installation and correct system's set-up instructions;

Chapter 8 – System Power-ON: it contains the procedure for the first system's Power-ON together with a first check of its correct operation;

Appendix A – Front Panel of the SY1527 system: a useful reference figure of the SY1527 Front Panel, including the Primary Power Supply and the Power Supply Units.

1.2 Conventions

The conventions adopted all through this guide are briefly listed in the following.

1.2.1 Safety rules

The user is requested to pay particular attention to the parts of the document containing the following terms:

WARNING:

Warning statements identify conditions or practices that could result in injury or loss of life.

CAUTION:

Caution statements identify conditions or practices that could result in damage to this product or other property.

Please pay particular attention to the grey areas where warning and caution statements are emphasised, as shown in the following examples:



CAUTION

PLEASE NOTE THAT THE BOTTOM, TOP AND SIDE GRIDS OF THE FAN TRAY UNIT MUST NOT BE COVERED UNDER ANY CIRCUMSTANCES!



WARNING

DO NOT OPERATE WITHOUT COVERS!

1.2.2 Electrical signal specifications

The polarity of the electrical signals can be chosen via software by the user. As a consequence, in this guide the following convention has been adopted:

TRUE: an electrical signal is indicated as TRUE when it is active.

FALSE: an electrical signal is indicated as FALSE when it is not active.

2. General description of the system

This preliminary section contains a short description of the SY1527 system with a summary of its main features and technical specifications.

A detailed description of system parameters and operating modes can be found in the *User's Manual*.

2.1 Overview

The SY1527 system is the fully equipped, large scale experiment version of a new line of power supply systems which represent CAEN's latest proposal in the matter of High Voltage and Low Voltage Power Supplying. This system outlines a completely new approach to power generation and distribution by allowing to house, in the same mainframe, a wide range of boards with different functions, such as High/Low Voltage boards, generic I/O boards (temperature, pressure monitors, etc.) and branch controllers, where the latter are used to control other remote generators and distributors.

Modularity, flexibility and reliability are the key-points of its design, enabling it to meet the requirements of a wide range of experimental conditions. The latter range from those of LHC experiments, in which the system's features find prior application, to those of other less challenging, but still demanding, High Energy Physics experiments.

The mainframe is housed in a 19"-wide, 8U-high euro-mechanics rack and hosts four main sections (refer to Fig. 2.1):

- the *Board Section*, with 16 slots to house boards, distributors and branch controllers;
- the *Fan Tray Section*, housing 6 fans disposed on two rows;
- the *Power Supply Section*, which consists of the primary power supply and up to 3 power supply units;
- the *CPU and Front Panel Section* which includes all interface facilities.

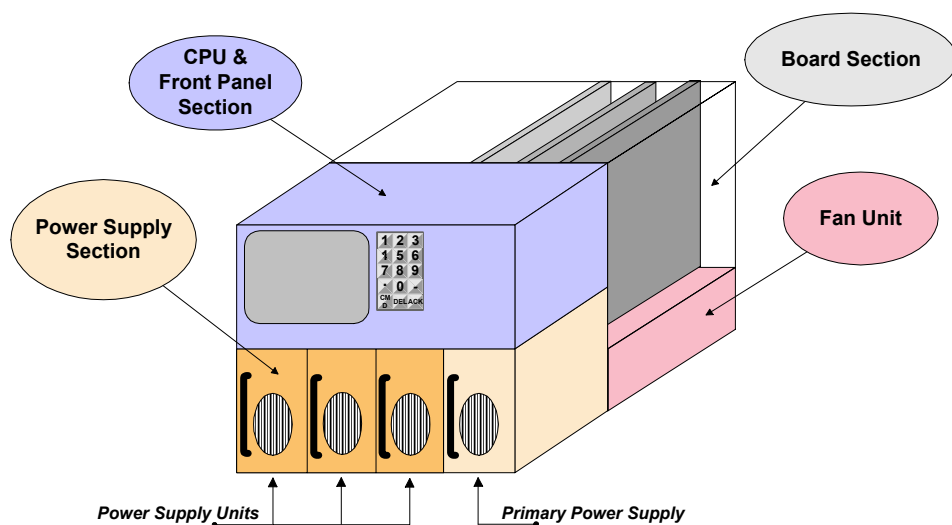

Fig. 2.1 – Layout of the main mechanical sections of the SY1527 mainframe

The User interface features the usual friendliness of the previous CAEN systems which now also includes a 7.7" colour LCD. A wide choice of communication interfaces provides full compatibility with the previous systems and the possibility of controlling heterogeneous external devices.

Modularity has been one of the leading criteria in the system design and development: both the *Power Supply Section* and the *Board Section* are completely modular. The *Power Supply Section* allows different configurations with up to 3 power supply units per mainframe (up to 2250 W), while the *Board Section* can house up to 16 boards able to fulfil different functions. A new line of boards and distributors, analogous with those available for the SY527 system and a set of branch controllers has been specially developed for this new system. The minimum system configuration consists of the primary power supply, one Power Supply Unit and one board.

The concept of modularity has been extended up to the possibility of arranging 'clusters' constituted by one 'intelligent' SY1527 system able to drive other 'non-intelligent' systems, i.e. systems without CPU (to be implemented). The connections among the systems constituting the cluster are realised through a new CAEN interface, the Local Net.

The extreme system flexibility, which allows to house indifferently, inside the same mainframe, boards with different functions, is further enhanced by the possibility of developing *ad-hoc* boards and even complete custom peripheral systems. The latter, actually, can be designed specifically for on-detector installation. All the custom electronics can be however remotely controlled by single boards which are inserted in the SY1527 mainframe and act as branch controllers.

Fast, accurate set-up and monitoring of system parameters (14-bit resolution on Voltages and Currents with standard boards) is available for each branch controller thanks to the use of one microprocessor per slot. All the operational parameters are stored in a non-volatile memory (EEPROM) to be still available after Power-Off. The parameters can be controlled either via CAEN traditional built-in links (RS232, H.S. CAENET) or via CERN-approved Fieldbuses or via Ethernet (TCP/IP). Programmable handling of parameters and errors is available as well.

Channel trip control on other crates is performed via four external differential trip lines. A sophisticated trip handling software allows to control and correlate trip conditions on the channels of the crate as well as of other crates connected to it.

Easy access to the computing core and peripherals and live insertion and extraction of the boards, which reduces the global down time, completes the system flexibility.

Easy interfacing is another key-point of the SY1527 system. Thanks to the H.S. CAENET interface, the system ensures full communication compatibility with the previous models. Besides the RS232 interface and Ethernet (TCP/IP) provided with the standard version of the system, CAN-bus can be furnished on request, as well as special boards featuring optical links for remote communications. The Power Supply Section and Board Section can be externally synchronised via front panel connectors.

Secure access to the system via Intranet is foreseen together with a multilevel management of custom User's profiles. In particular, three different access levels have been implemented: *Guest*, *User* and *Administrator*, each of which with password protection.

Handy maintenance and upgrading, which constitute a major issue in the reliability of a system, are further guaranteed by the possibility of accessing and servicing the system

via network facilities. Actually, Telnet and WWW access facilities allow system's remote debugging and technical support, including future firmware upgrading.

2.2 Short Functional description

A block diagram of the SY1527 system is shown in Fig. 2.2, p.13.

A single crate can host up to 16 Channel Boards, which can be chosen in a wide range of plug-in boards, from standard HV/LV boards and floating boards to generic I/O boards monitoring external parameters or branch controllers. All the types of boards can be freely mixed in the same crate, fitting the user's needs.

Both the System's Power-On and the Channel Out Enable can be performed either locally or remotely. Remote Enable is performed by sending the proper input signal via the relevant front panel connector.

Each crate may be controlled either locally or remotely. Local control is performed manually through a key-pad, a compact switch and a 7.7" colour LCD located on the front panel. Remote control is feasible via the interface connectors located on the front panel. These include a RS232 interface, which can be used to plug in a video terminal (ANSI VT100 or compatible) or a IBMTM PC, a VGA port to connect an external standard VGA monitor and a PS/2 connector to plug in an external keyboard. The usual HIGH SPEED (H.S.) CAENET interface is also available to daisy-chain more SY1527 crates (up to 99 crates).

A sophisticated Software User Interface is available both in local or remote control, featuring symbolic names for channels, custom status displays and other features designed to help the management of a large number of channels.

Programmable parameters for each power channel include two voltage values (**V0set**, **V1set**) and two current limit values (**I0set**, **I1set**). The switching from one value to the other is performed via two external (NIM or TTL) input levels (VSEL, ISEL). The maximum rate of change of the voltage (Volt/second) may be programmed for each channel. Two distinct values are available, **Ramp-Up** and **Ramp-Down**. Any command to change the voltage will result in a linear voltage increase or decrease with time, the rates being determined by the Ramp-Up or Ramp-Down parameters, respectively.

For the *boards with programmable current hardware protections* the ISET channels' values represent a software-controlled hardware protection on the channels' currents. In this case the channel cannot draw a current higher than its programmed limit.

For the *boards with fixed current hardware protections*, i.e. boards which have the current hardware protection fixed to a common value for all the channels, the IMON values are used to signal a fault, but the channels can draw a current larger than the ISET values.

In both cases, if a channel tries to draw a current larger than the programmed limit, it is signalled to be in OVERCURRENT. The System detects this state as a fault and reacts according to the setting of the **TRIP** parameter, namely:

1) *TRIP = infinite (constant CURRENT mode)*

If the Board has programmable current hardware protections, the output voltage is varied to keep the current below the programmed limit. The channel acts like a current generator.

If the Board has fixed current hardware protections, the output current is permitted to exceed the ISET value; the channel acts like a current generator only if the maximum current value is reached.

2) TRIP = finite value (**TRIP mode**)

In this case, the channel behaves as in the constant CURRENT mode for a time equal to the finite value set as TRIP parameter, and then it is switched off according to the selected **Power-Down** option (Kill/Ramp-Down). If the **Kill** option is selected, the channel will be switched off immediately. If the **Ramp-Down** option is selected, the voltage will drop to zero at a rate determined by the value of the **Ramp-Down** parameter programmed for that channel.

Other front panel signals and relevant LEDs are foreseen to signal the channel status, such as OVERVOLTAGE, UNDERVOLTAGE, CHANNEL ON and TRIP. Another set of LEDs warn about possible fault conditions in the system operation (OVER TEMPERATURE, FAN FAILURE, POWER FAILURE). For a detailed description of the channel parameters please refer to the *User's Manual*. A description of all front panel signals and LEDs can be found in Section 4.3, p.36 of this guide.

A RESET can be generated either manually via a front panel button or remotely by sending a proper signal through the relevant connector. In both cases it is possible to reset only the system's CPU or both the CPU and the boards, depending on the duration of the RESET signal.

The System may be instructed to react to a Power On or to a Restart bringing all the channels from zero to the programmed value without the user's intervention via the **Power-On** parameter. If this option is enabled, the System will recover smoothly from a power failure or RESET, automatically restoring the status it had before the power was interrupted.

KILL and INTERLOCK functions have also been implemented and allow to drop the channel output voltage to zero, independently from the Ramp-Down parameter set.

For a detailed description of all system control commands and monitoring signals please refer to the *User's Manual*.

In order to protect the System from improper use, a multilevel management of the user's profiles has been foreseen, including the possibility of having password protection for each channel or group of channels. In particular, three different login levels are available: *Guest*, *User* and *Administrator*, each with different levels of access ability to the system parameter monitoring and setting. Moreover, the possibility of defining preferred custom environments is foreseen for each single user.

Daisy-chain configuration of more SY1527 crates can be achieved by using the H.S. CAENET connectors located on the front panel. The chain can be controlled remotely by a SY1527 system configured as CAENET Controller allowing for *Multicrate Operation*, i.e. the possibility of controlling and monitoring interactively the daisy-chained crates one at a time, either from any one of the SY1527 chain's crates or from a PC or video terminal externally connected to any one of the crates. Moreover, in *Multicrate Operation* it is possible to connect to the chain a SY127 system, equipped with a A128HS board, and interact with it via H.S. CAENET. The same operation is also possible with a SY527 system.

The Ethernet interface further extends the access facilities to the system: it allows the use of a Browser or just a Telnet connection to monitor and control interactively each crate connected to the network. This type of link, which can be reduced to the Customer's Intranet in order to have secure access, allows to perform remotely a wide range of tasks, such as system debugging, firmware upgrading and even technical

support. A special software interface has been developed for monitoring and setting of the system parameters from TCP/IP environment.

Further remote control interfaces are available on request and can be inserted into the expansion slots on the front panel.

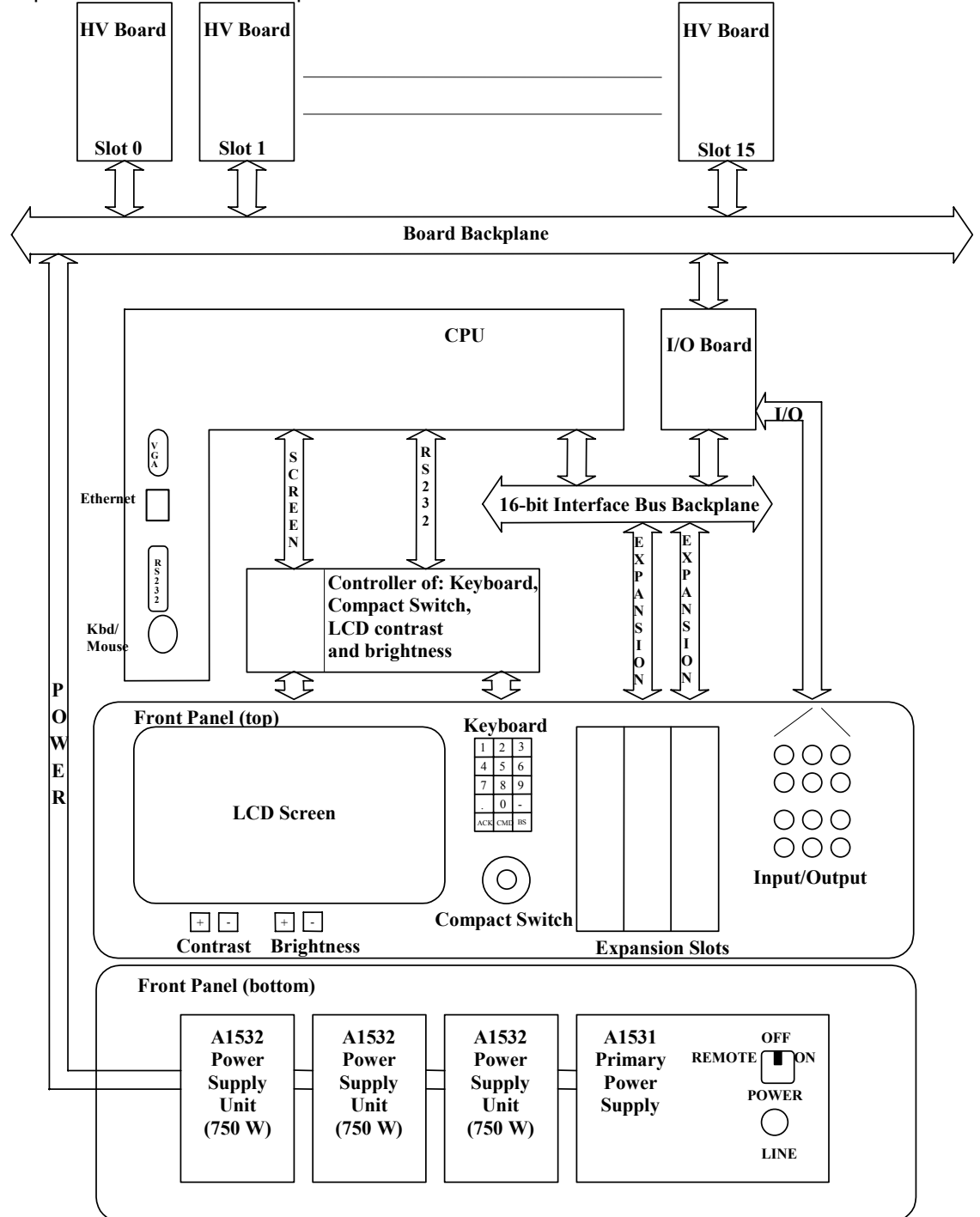

Fig. 2.2 – Block diagram of the functional parts of the SY1527 system

2.3 Technical specification table

Table 2.1 - Technical specifications of the SY1527 mainframe: general

Packaging	- 19"-wide, 8U-high Euro-mechanics rack; - Depth: 720 mm.
Weight	-Mainframe (*): 24 kg -Mod. A1532: 3.2 kg
Power Requirements	<i>Voltage range:</i> 100/230 V <i>Frequency:</i> 50/60 Hz <i>Power:</i> 3400 W
Max. number of boards per crate	16
Max. number of Power Supply Units per crate	3
Primary power supply output	± 12 V, 8 A +5 V, 20 A
Power supply unit output	+48 V, 15.6 A
Max. output power	2250 W
Operating temperature	From 0°C (dry atmosphere) to +40°C
Storage temperature	From -20°C (dry atmosphere) to +50°C

(*): One Primary Power Supply (Mod. A1531) and one Power Supply Unit (Mod. A1532) are included; boards are not included.

Table 2.2 - Technical specifications of the SY1527 mainframe: front and rear panel components

(refer to the figure in Appendix A)

<p>Displays <i>(I/O control section)</i></p>	<ul style="list-style-type: none"> - GEN, red LED, lights up when GENERAL STATUS signal, corresponding to a logic combination (defined by the user) of OVC, UNV, OVV, TRIP, is TRUE; - CH-ON, red LED, lights up when at least one channel is ON; - OVC, UNV, TRIP, OVV, red LEDs, light up when at least one channel is in <i>Over Current, Under Voltage, Trip, Over Voltage</i> condition, respectively; - RSTFLAG, red LED, lights up after a RESET; - CHK PASS, green LED, lights up when the initial system check has been performed successfully and the system is ready. - VSEL, ISEL, green LEDs, light up when the relevant connectors for voltage and current selection, respectively, are TRUE; - KILL, green LED, lights up when the system is in KILL condition; - NIM, TTL, green LEDs, light up when the relevant standard is selected; - RESET, red/orange LED, lights up when a RESET occurs: it is initially red and then becomes orange, depending on the duration of the RESET signal; - LOCAL ENABLE, REM ENABLE, red LEDs, light up, respectively, when the <i>Local Enable</i> mode is selected and when the <i>Remote Enable</i> mode is selected and the proper REM EN signal is sent in; - OVERTEMP, FAN FAILURE, PWR FAILURE red LEDs, light up when the <i>Over Temperature, Fan Failure and Power Failure</i> condition, respectively, occurs; - INTERLOCK, red LED, lights up as the system is in INTERLOCK condition. - LOCAL NET, CAENET, red LEDs, light up when the relevant connectors are in activity; - MASTER, red LED, lights up when the HV SYNC clock is internally generated.
<p>Displays <i>(Power Supplies)</i></p>	<ul style="list-style-type: none"> - OK, yellow LED, lights up when the system is turned on. - +5, +12, -12, +48, green LEDs, light up as the relevant power supply is present; - MAIN, orange LED, when lit up, it warns that the system is connected to the mains and the MAIN switch on the rear panel is in position 1.
<p>Switches</p>	<ul style="list-style-type: none"> - NIM/TTL switch for the selection of the level standard of the output signals; - LOCAL ENABLE/DISABLE/REMOTE ENABLE switch, which allows, respectively, to enable the channels locally or to disable them or to allow their remote enable via the proper ENABLE input signal; - INTERLOCK CLOSED/OPEN switch to select if the INTERLOCK function is active when the contact is closed or open, respectively. - MAIN switch (rear panel) to power the Power Supply Section; - POWER ON key (front panel, primary power supply) to power on the system locally or to enable its remote power on.
<p>Buttons</p>	<p>RESET push button: if $T_{RESET} > T_{RCPU} = 100 \div 200 \text{ ms}$ → CPU is reset; if $T_{RESET} > T_{RCH} = T_{RCPU} + 900 \text{ ms}$ → CPU, boards are reset and the channels are turned off. The Reset must be enabled via the RESET FLAG software window.</p>
<p>Local Control Interfaces</p>	<ul style="list-style-type: none"> - 7.7" colour LCD screen, with brightness and contrast control buttons; - 15-key keypad; - compact switch (8 directions + press action).
<p>Remote Control Interfaces</p>	<ul style="list-style-type: none"> - H.S. CAENET; - LOCAL NET (<u>to control non-intelligent systems ONLY</u>); - One PS/2 connector for external PC keyboard; - VGA-standard connector for external VGA monitor; - ETHERNET (TCP/IP); - RS232 interface for external VT100 or PC.
<p>Optional Interfaces</p>	<ul style="list-style-type: none"> - CAN-bus.

Table 2.3 - Technical specifications of the SY1527 mainframe: input and output signals

(refer to the figure in Appendix A)

INPUTS	VSEL:	Std. NIM/TTL; 00-type LEMO connector. <i>Function:</i> channel voltage selection.
	ISEL:	Std. NIM/TTL; 00-type LEMO connector. <i>Function:</i> channel current selection.
	RESET:	Std. NIM/TTL; 00-type LEMO connector. <i>Function:</i> RESET from the front panel. If the duration of the RESET signal is $> T_{RCPU}=100\div 200$ ms, only the CPU is reset; if it is $> T_{RCH}=T_{RCPU} + 900$ ms, also the boards are reset and the channels turned off. The Reset must be enabled via the RESET FLAG software window.
	KILL:	Std. NIM/TTL; 00-type LEMO connector. <i>Function:</i> KILL from the front panel: it turns all channels off.
	ENABLE:	Std. NIM/TTL; 00-type LEMO connector. <i>Function:</i> remote enable.
	INTERLOCK:	open/closed contact; 00-type LEMO connector. <i>Function:</i> INTERLOCK command: it turns all the channels off as it is open/closed, according to the position of the relevant switch.
	REMOTE IN:	+12 V, 50 mA max., electr. Insul.; tol.: -40%÷+20%; 00LEMO connector. <i>Function:</i> remote power-on of the system.
OUTPUTS	OVC:	Std. NIM/TTL (selectable); 00-type LEMO connector. <i>Function:</i> at least one channel is in <i>Over Current</i> .
	UNV:	Std. NIM/TTL (selectable); 00-type LEMO connector. <i>Function:</i> at least one channel is in <i>Under Voltage</i> .
	OVV:	Std. NIM/TTL (selectable); 00-type LEMO connector. <i>Function:</i> at least one channel is in <i>Over Voltage</i> .
	CH-ON:	Std. NIM/TTL (selectable); 00-type LEMO connector. <i>Function:</i> at least one channel is ON.
	RST FLAG:	Std. NIM/TTL (selectable); 00-type LEMO connector. <i>Function:</i> a RESET occurred.
	CHK PASSED:	Std. NIM/TTL (selectable); 00-type LEMO connector. <i>Function:</i> initial system check successful and system ready.
	TRIP:	Std. NIM/TTL (selectable); 00-type LEMO connector. <i>Function:</i> at least one channel in <i>Trip</i> condition.
	GEN:	Std. NIM/TTL (selectable); 00-type LEMO connector. <i>Function:</i> GENERAL STATUS indication; corresponds to the logic combination (defined by the user) of OVC, UNV, OVV, TRIP.
	REMOTE OUT:	+12 V level, referred to the crate ground; tolerance: -20% ÷ +20%; 00-type LEMO connector. <i>Function:</i> remote power-on of the adjacent daisy-chained crate.
I/O	HVSYNC:	Bidirectional differential signal ; 2-pin LEMO connectors. <i>Function:</i> sync clock for the PWS Units ((RS485 Std., 1.25 MHz).
	LOCAL NET:	Bidirectional differential signal; 2-pin LEMO connector. <i>Function:</i> LOCAL bus for the control of non-intelligent systems <u>ONLY</u> .
	CAENET:	Bidirectional CAENET; 00-type LEMO connector. <i>Function:</i> H.S. CAENET interface.
	TRIP IN/OUT:	Bidirectional differential signal; 5x2-flat connectors. <i>Function:</i> external TRIP lines to handle TRIP conditions.

All the above signals, except for the REMOTE IN/OUT, are referred to a common ground (COMMON GROUND) and are galvanically insulated up to 150 V with respect to the ground of the crate (CRATE GROUND).

3. Description of the mechanical parts

This section contains a description, from a mechanical point of view, of the parts which constitute the SY1527 mainframe's universal multichannel power supply system.

3.1 The SY1527 mainframe and its mechanical parts

The SY1527 system is hosted in an 8U-high, 19"-wide (84TE) EURO-mechanics rack. The depth of the rack is about 720 mm.

The SY1527 mainframe can be essentially divided into four main mechanical sections (refer to Fig. 2.1, p.9):

- Board section;
- Fan tray unit;
- CPU and front panel section;
- Power supply section.

Fig. 3.1 shows these mechanical components of the four sections in some further detail.

The higher 6U-high section of the mainframe's rear part can host up to 16 boards, while the lower 2U-high section contains the fan tray unit.

On the front part of the mainframe the higher 4U-high section hosts the front panel and the CPU section, while the lower 4U-high section is devoted to the Power Supply Units and to the Primary Power Supply (the latter is always located on the bottom right).

The mainframe structure is made of alodine-treated aluminium which was chosen for its high conductivity and light weight. Two panels cover the sides of this inner frame, while the rear panel and the front panel complete the coverage of the structure. All the panels are fixed with conductive screws in order to ensure electrical conductivity.

A description of each part can be found in the following sections.

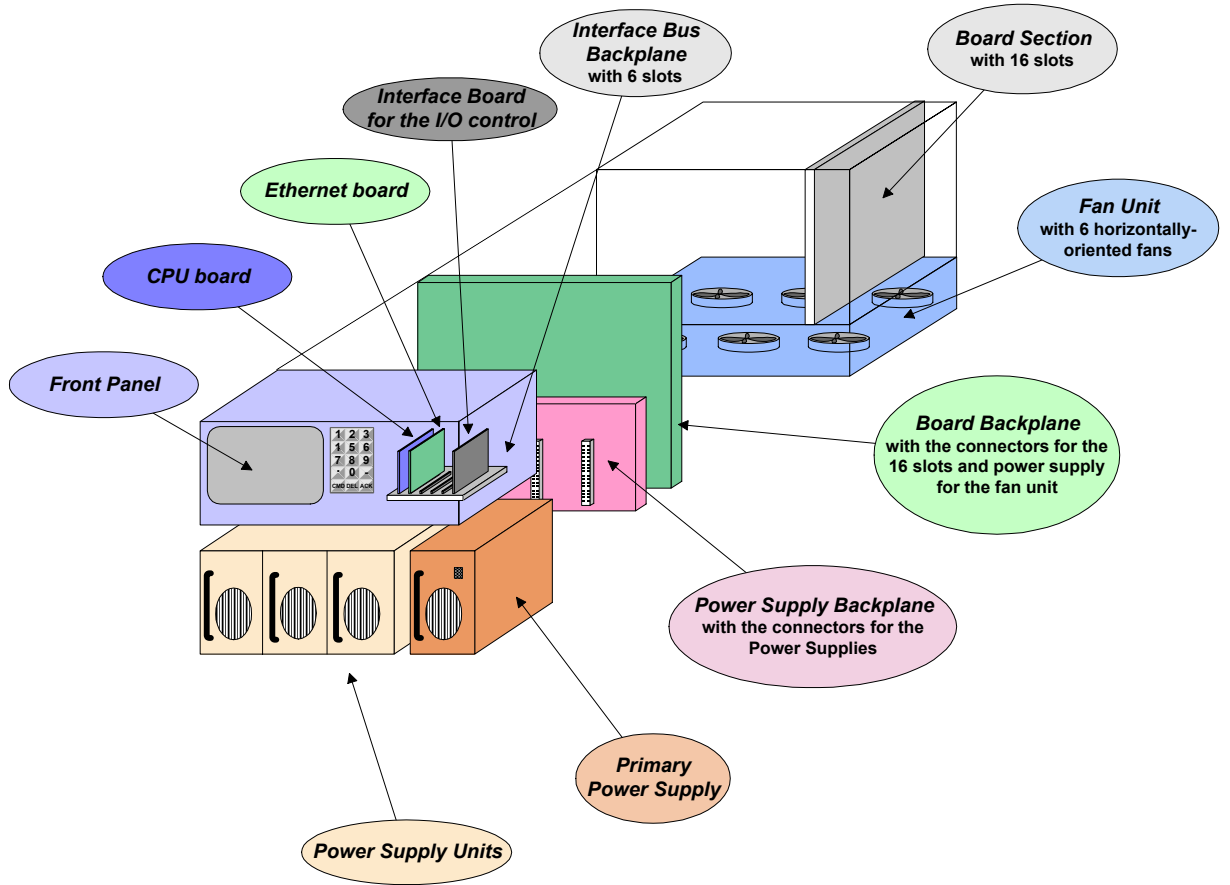

Fig. 3.1 – Details of the mechanical parts contained in the SY1527 mainframe

3.2 Board Section

This section is located in the mainframe's rear upper 6U-high part and hosts the 16 slots for the insertion of boards (refer to Fig. 2.1, p.9).

This section is empty when it is delivered to the customer. It can house up to 16 vertically positioned boards, which can be High Voltage or Low Voltage (HV/LV) boards, Distributors, etc.. The boards must be 6U-high and slide on special guides until they are plugged into the relevant connectors of the Board Backplane.

The 16 slots are numbered starting from left (**Slot 0**) to right (**Slot 15**). They are completely equivalent, i.e. the user can insert in each slot either a HV/LV board or a distributors, indifferently. The HV/LV boards can be Positive, Negative or Floating boards. At Power-On the processor will scan all the slots to find out where the boards are plugged in and what kind of boards they are.

Section 3.2.1 illustrates the Board Backplane, while Sections 3.2.2, 3.2.3 and 3.2.4 are devoted to a wide range of boards compatible with the SY1527 system, specifically to the HV/LV, Floating and Miscellaneous Boards, to the Distributors and to the Branch Controllers.

3.2.1 Board Backplane

The Board Backplane (refer to Fig. 3.1, p.19) houses 16 96-pin EUROCARD connectors for the boards' power supply and 6 connectors to DC supply the fan tray unit.

The Board Backplane is powered by the Power Supply Backplane (refer to Section 3.4.1, p.23) which is directly connected to the Power Supply Units.

3.2.2 High and Low Voltage, Floating and Miscellaneous boards

For further details, please refer to *User's Manual* of the relevant model.

3.2.3 Distributors

For further details, please refer to *User's Manual* of the relevant model.

3.2.4 Branch Controllers

For further details, please refer to *User's Manual* of the relevant model.

3.3 Fan tray section

This section is located in the mainframe's rear lower part and is housed in a 2U-high, 400-mm deep box (refer to Fig. 2.1, p.9 and Fig. 3.1, p.19). This section hosts six fans for

the system's cooling. The six fans are disposed on two rows and are DC supplied through the relevant connectors placed on the Board Backplane.

In order to make more uniform the system's ventilation, the fans have been placed about 3 cm far from the boards so that ventilation from all sides is adequate. As a consequence, **DO NOT COVER THE BOTTOM AND TOP GRIDS** under any circumstances.



CAUTION

**THE BOTTOM AND TOP GRIDS OF THE FAN TRAY UNIT
MUST NOT BE COVERED UNDER ANY CIRCUMSTANCES!**



CAUTION

**THE EXTRACTION OF THE FAN TRAY UNIT BOX CAN BE PERFORMED BY
QUALIFIED PERSONNEL ONLY!**

The position of the fan tray inside the mainframe (looking from the rear panel) and the direction of the air flow are shown in Fig. 3.2.

The fans start to work as soon as the system is powered ON, either remotely via the relevant input signal or locally by turning on the power-ON key (refer to Section 3.4.2, p.23).

Please note that the maximum allowed temperature for the operation of the fan tray unit is 40°C.



CAUTION

**THE MAXIMUM ALLOWED TEMPERATURE
FOR THE OPERATION OF THE FAN TRAY UNIT IS 40°C!**

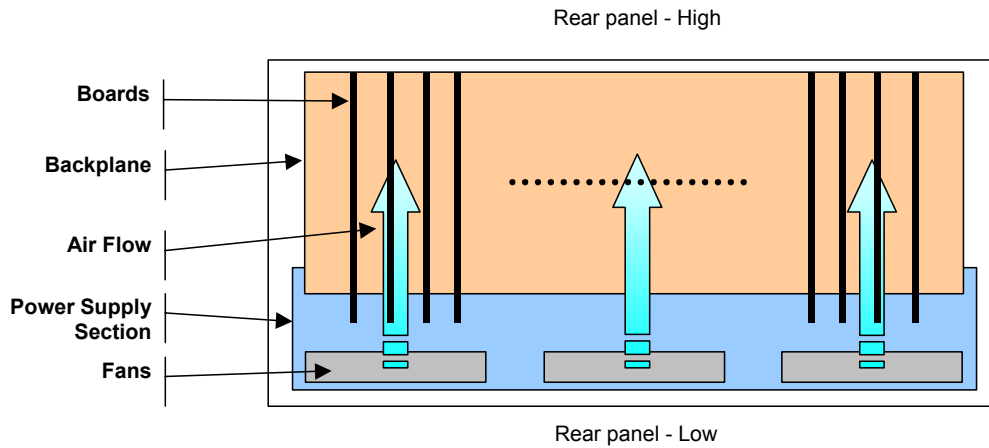

Fig. 3.2 –Air flow from the fan tray unit into the board section



CAUTION

**THE DISTANCE FROM THE TOP OF A CRATE AND ANY OTHER OBJECT
MUST BE AT LEAST 15 CM!**

3.4 Power Supply section

This section is located in the the mainframe’s front lower 4U-high part. It has four housings where are placed the Primary Power Supply of the whole system logic (on the bottom right) and up to three Power Supply Units (refer to Fig. 2.1 and Fig. 3.1, p.19). The housings are equipped with special guides on which the power supplies slide until they are plugged into the relevant power supply backplane.

The housings are numbered starting from right (**Housing 0**) to left (**Housing 3**).

The Primary Power Supply (Model A1531) furnishes the +/-12 V and +5 V at 320 W for the system logic circuitry, while the +48 V at 750 W for the boards is generated by the Power Supply Units (Model A1532).

The minimum system configuration consists of the Primary Power Supply and one Power Supply Unit. The Primary Power Supply must always br placed in the slot on the right, while the Power Supply Unit can be placed in any of the three slots left. Both the Primary Power Supply and the Power Supply Units have bias pins for insertion into the relevant mating holes of the backplane. In order to avoid a misplacement of the Primary Power Supply, the latter has a bias pin placed in a different position with respect to that of the Power Supply Units’ bias pins.

WARNING: Both the primary power supply and the power supply units can be inserted or extracted from the appropriate housing only if the system main switch located on the rear panel is OFF (i.e. in the \emptyset position) and the system is unplugged from the mains. Please refer to Fig. 3.6, p.35 for the exact location of the main switch.



WARNING

**DO NOT INSERT OR EXTRACT ANY POWER SUPPLY
BEFORE THE SYSTEM IS TURNED OFF AND UNPLUGGED FROM THE MAINS!**

3.4.1 *Power Supply Backplane*

The power supply backplane (refer to Fig. 3.1, p.19) houses:

- connector for the primary power supply;
- three connectors for the Power Supply Units;
- connecting terminals to the mains.

The Power Supply Backplane is plugged into the Board Backplane which supplies the 16 boards and the fan tray unit (refer to Section 3.2.1). The power supply backplane is directly connected to the mains through connecting terminals. The power supply is transferred from the Power Supply Backplane to the Board Backplane.

3.4.2 *Primary Power Supply (Mod. A 1531)*

The Primary Power Supply (Model A1531), which is always present even in the basic system configuration, furnishes the $\pm 12\text{ V}$ and $+5\text{ V}$ at 320 W for the system logic circuitry and is always housed in the slot on the right (Housing 0, refer to Fig. 3.1, p.19).

The front panel of the primary power supply is shown in Fig. 3.3. On its top right there is the power-ON key to turn the system on (the main switch on the rear panel just enables the system to be powered, but the system is not powered until the power-ON key is turned on).

The turn-ON key has three different positions:

- the central position corresponds to the system OFF;
- the right position turns the system ON locally;
- the left position enables the system to be turned ON remotely.

Underneath the turn-ON key an orange LED (**MAIN**) warns, when it lights up, that the system is connected to the mains and the switch on the rear panel is on (i.e. in position 1).

Four LEDs, placed at the bottom of the panel, light up when the following conditions are met:

- **OK**, yellow LED; lights up when the system is ON;
- **+5**, red LED; lights up when the +5 V power supply is present; if off, it indicates that there is a fault;
- **+12**, red LED; lights up when the +12 V power supply is present; if it is off it indicates that there is a fault;
- **-12**, red LED; lights up when the -12 V power supply is present; if it is off it indicates that there is a fault.

On the bottom right there are two LEMO connectors (REMOTE IN and OUT) which allow to turn the system on remotely:

- **REMOTE IN**; 00-type LEMO connector, 12 V (tolerance: -40% ÷ +20%), 50 mA max, electrically insulated; it is used to turn the system on remotely.
- **REMOTE OUT**; 00-type LEMO connector, 12 V (tolerance: -20% ÷ +20%), 50 mA max, 5–10 sec delay with respect to the power-ON of the system, referred to the crate ground; it is used in daisy-chain configurations to turn on remotely the adjacent daisy-chained crate.

The front panel is completed by a grid for the cooling of the power supply unit and a handle, on its left, to plug the module into the relevant backplane connector.



Fig. 3.3 – Front panel of the Primary Power Supply (Mod. A1531)

A summary of the main input and output electrical features of the primary power supply are shown in Table 3.1.

WARNING: The primary power supply can be inserted or extracted from the appropriate housing only if the system is turned off and unplugged from the mains.



CAUTION

DO NOT COVER THE COOLING GRID!

Table 3.1 – Mechanical and Electrical features of the A1531 Primary Power Supply

Mechanical features	<ul style="list-style-type: none"> - 20TE-wide, 4U-high mechanics; - Depth: 250 mm; - Equipped with sliding guides.
Input features	<ul style="list-style-type: none"> - Monophase input from 100 Veff to 230 Veff, 50-60 Hz with Power Factor Correction (PFC); - Input current limitation at Power-ON less than 15 A (230 Veff input); - Soft start; - Hold up time \geq 20 ms.
Output features	<ul style="list-style-type: none"> - Output voltage: +12 V, 8 A; -12 V, 8 A; +5 V, 20 A.

3.4.3 Power Supply Units (Mod. A1532)

The Power Supply Units (Model A1532) deliver voltage (+48 V, 750 W) for the system boards supply. The SY1527 mainframe can house up to three A1532 units allowing to reach a 2250 W maximum output power.

Any configuration of the SY1527 system includes at least one A1532 unit for the power supply of the board section.

Each of the A1532 Power Supply Units can be placed in any of the housings from #1 to #3 on the mainframe's front part, i.e. any housing except for the first housing on the right (Housing #0) which is reserved to the Primary Power Supply (refer to Fig. 3.1, p.19). Both the Primary Power Supply and the Power Supply Units have bias pins to be inserted into the relevant mating holes of the backplane. In order to avoid a misplacement of the Primary Power Supply, the latter has a bias pin placed in a different

position with respect to that of the bias pins of the Power Supply Units. When the system is delivered to the customer, the housings which are not used are covered with a panel.

The front panel of the A1532 Power Supply Unit is shown in Fig. 3.6. On the bottom left there is a green LED (+48) which lights up when the +48 V power supply is present; if it is off it indicates that there is a fault.

The front panel of each Power Supply Unit has a grid for the cooling of the unit. Moreover, a convenient handle allows to insert or extract easily the unit from the relevant backplane connector.

The A1532 unit has been designed to be automatically disconnected from the output bus in case of a unit malfunctioning. This allows to the other units to keep on working properly even if one of the units does not operate in a proper way.



Fig. 3.4 – Front panel of the Power Supply Unit (Mod. A1532)

A summary of the main input and output electrical features of the primary power supply are shown in Table 3.2.

WARNING: The power supply units can be inserted or extracted from the appropriate housings only if the system is turned off and unplugged from the mains.

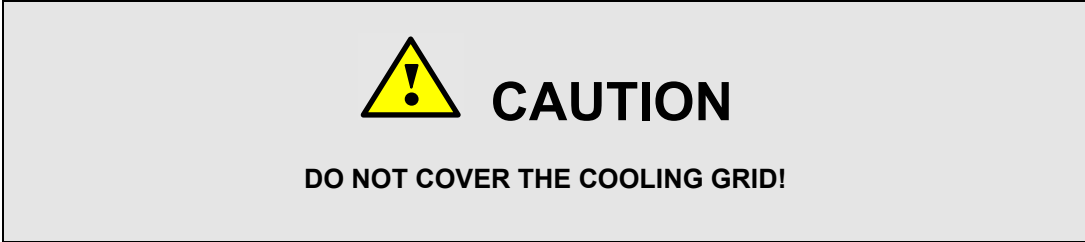

Table 3.2 – Mechanical and Electrical features of the A1532 Power Supply Unit

Mechanical features	<ul style="list-style-type: none"> - 20TE-wide, 4U-high mechanics; - Depth: 250 mm; - Equipped with sliding guides.
Input features	<ul style="list-style-type: none"> - Monophase input from 100 Veff to 230 Veff, 50-60 Hz with Power Factor Correction (PFC); - Input current limitation at Power-ON less than 15 A (230 Veff input); - Soft start; - Hold up time ≥ 20 ms.
Output features	<ul style="list-style-type: none"> - Output voltage: +48 V, 15.6 A; - Parallel output feasibility.

3.5 CPU section

This unit contains the system’s intelligent core and is fully contained inside an extractable metal box which ensures the EM shielding, making maintenance easier (refer to Fig. 2.1, p.9). It can be divided into the following parts:

- Interface Bus Backplane;
- CPU Board;
- Interface Board;
- Ethernet board.

The CPU Board, the Ethernet board and the Interface Board are plugged into the Interface Bus Backplane (ISA bus) as shown in Fig. 3.1, p.19. Additional custom interface boards, such as CAN bus, can be inserted by qualified personnel into the bus for further communication facilities.



**THE EXTRACTION OF THE CPU SECTION BOX CAN BE PERFORMED BY
QUALIFIED PERSONNEL ONLY!**

3.5.1 Interface bus backplane

The Interface bus backplane is an AT standard passive ISA bus with 6 16-bit slots. Two of these are occupied by the Interface Board and by the CPU Board (Fig. 3.1, p.19), while two of the four slots left are available for additional interface boards (refer to Section 3.5.4, p.29 for further details on the additional interface boards available for the SY1527 system).

3.5.2 CPU board

The CPU board houses a microprocessor which has direct control on the crate operation. It fulfils the following basic functions:

- direct control and monitoring of the channels;
- manual and remote interfaces;
- power supply control;
- temperature monitoring;
- fan tray monitoring.

The board houses as well an RS232 serial port interface, a VGA standard connector, a PS/2 connector and the Ethernet 10/100baseT interface. The interfaces and connectors are accessible on the front panel. The Ethernet interface allows for network access facilities, such as access via INTRANET or INTERNET by using a standard Web Browser or a Telnet connection.

A software release has been specially developed for the use with a Web Browser: it allows monitoring and control of any crate connected to the network easily.

Secure access is guaranteed via a multilevel login profile management and password protection for single channels or groups of channels (refer to the *User's Manual* for details on this topic).

The possibility of accessing the crates via network allows for a remote technical support and firmware upgrading reducing both its cost and the time required for the operation.

3.5.3 Interface board

The Interface board is plugged into the ISA-bus of the CPU section (refer to Fig. 3.1, p.19). This board is the system's communication core and controls the following internal connections:

- status/control signals between the front panel and channel boards;
- status/control signals and bidirectional communications between CPU and channel boards;
- bidirectional communications between the CPU and the external peripherals;
- monitoring of power supply section and fan tray unit.

3.5.4 Additional interface boards

The additional interfaces which can be installed into the Interface Bus backplane are:

- CAN-bus;
- other boards according to customer's requests.

3.6 Front Panel

The frontal part of the SY1527 mainframe is shown in Fig. 3.5, p.30. It can be essentially divided into two main sections:

- the higher 4U-high section which consists of the actual Front Panel;
- the lower 4U-high section corresponding to the Power Supply Section.

For a detailed description of the Power Supply Section, please refer to Section 3.4, p.22.

The Front Panel features the following components:

- the 7.7" colour LCD monitor with a 15-key keypad and a compact switch;
- the Interface Bus section with three slots containing a RS232 interface, a VGA port, one PS/2 connector and additional peripherals;
- the I/O Control section which hosts I/O connectors and several displays and switches.

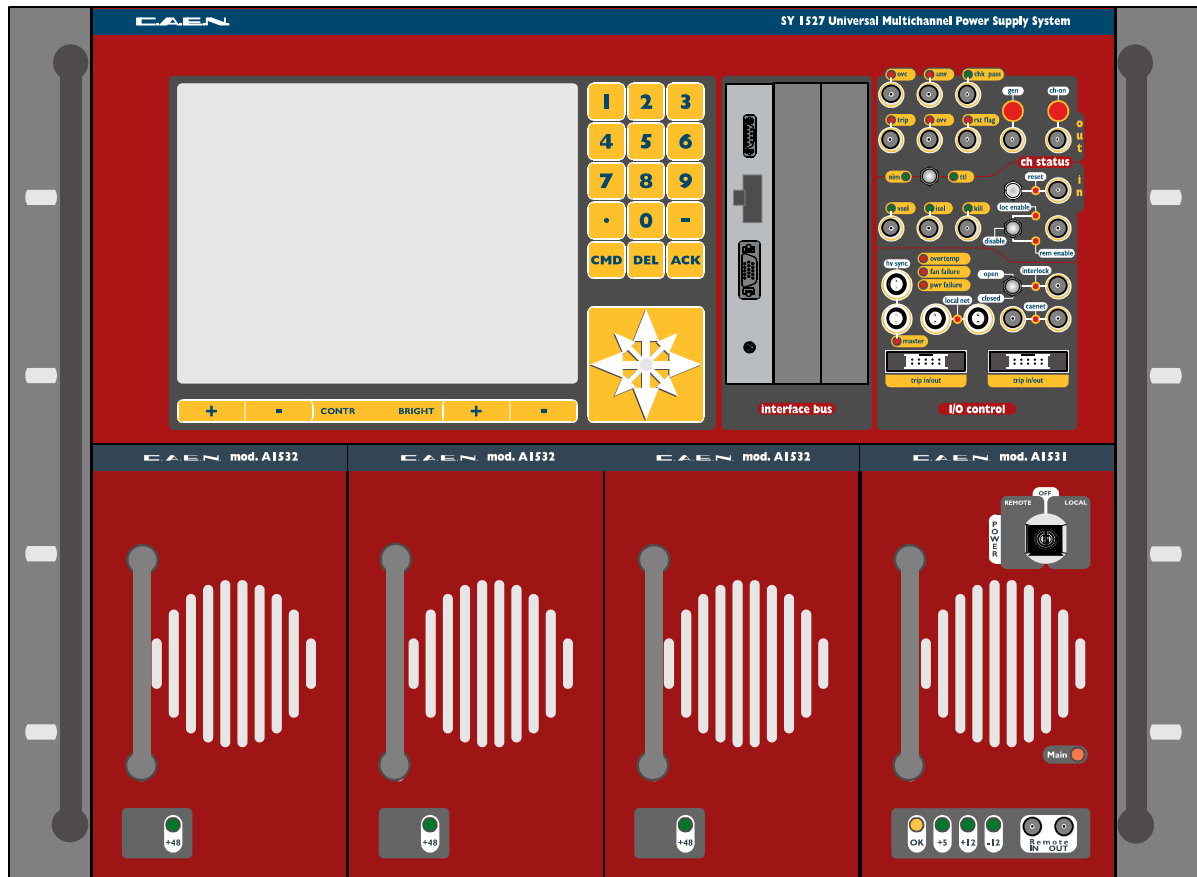

Fig. 3.5 – Front panel of the SY1527 system

3.6.1 **LCD screen, keypad and compact switch**

The crate is provided with a VGA-standard 7.7" colour LCD screen (640x480 resolution). Four buttons (**+/- CONTRAST** and **+/- BRIGHT**), placed just below the screen, allow to adjust the brightness and contrast of the monitor.

The keypad has 15 keys consisting of:

- 10 numerical keys from "0" to "9",
- the keys "+" and "-",
- the keys "CMD", "DEL" and "ACK".

The latter are the COMMAND, DELETE and ACKNOWLEDGE commands, respectively. The COMMAND key allows to select the *Menu Bar* in the software interface running in standalone operation or operation via terminal (refer to the *SY1527 User's Manual* for further details).

The DELETE key is the usual DELETE command of a standard keyboard.

The ACKNOWLEDGE key corresponds to the usual ENTER command of a standard keyboard.

The keypad is used for the manual set-up of the channel parameters. They allow as well to set the RS232 port configuration and the CAENET node address (the address of the crate).

The compact switch, placed underneath the keypad on the front panel, can assume 8 positions plus the press action. The latter corresponds to the command SPACEBAR from the keyboard.

The compact switch allows to move on the screen, by moving the lever toward one of its 8 directions, and to switch among the options available for the currently selected field by pressing the lever.

For further details on the use of these control devices, please refer to the *SY1527 User's Manual*.

3.6.2 **Interface Bus Section**

The Interface Bus section has three slots: the first slot on the left contains the RS232 interface, a VGA-standard connector, a PS2 connector and the Ethernet interface; the other slots can be used to host additional peripherals and, if not used, is covered with a metal panel. For the exact location of these four connectors on the front panel please refer to Fig. 3.5, p.30.

The RS232 interface allows to connect the system to an external ANSI VT100 (or compatible) video terminal or to a standard IBMTM PC. The PS/2 connector allows to plug in an external standard PC keyboard. These external components make easier the set-up of channel parameters and, in general, allow more friendly control of the system.

For a detailed description of the default interfaces and its mechanical and electrical specifications please refer to Section 4.3.3, p.38.

For a description of the peripherals which can be optionally housed in the two slot left please refer to Section 3.5.4, p.29.

3.6.3 I/O Control Section

The I/O Control section hosts the I/O connectors and several displays and switches for the system's control.

Output connectors

The upper part of this area contains the OUTPUT connectors and relevant displays for the check of the channel status.

Starting from left to right, these are:

- **OVC** (OVER CURRENT) output connector and relevant red LED – if it is TRUE (relevant LED on), it indicates that at least one channel is in *Over Current* condition.
- **UNV** (UNDER VOLTAGE) output connector and relevant red LED – if it is TRUE (relevant LED on), it indicates that at least one channel is in *Under Voltage* condition.
- **CHK PASS** (CHECK PASSED) output connector and relevant green LED – if it is TRUE (relevant LED on), it indicates that the initial check of the system has been successful and that the system is ready.
- **TRIP** output connector and relevant red LED – if it is TRUE (relevant LED on), it indicates that at least one channel is in *Trip* condition.
- **OVV** (OVER VOLTAGE) output connector and relevant red LED – if it is TRUE (relevant LED on), it indicates that at least one channel is in *Over Voltage* condition.
- **RST FLAG** (RESET FLAG) output connector and relevant red LED – if it is TRUE (relevant LED on), it indicates that a RESET occurred according to the user's settings (refer to the *User's Manual* for the setting of the conditions on the RESET FLAG, which allows as well to enable the different types of resets).

Moreover, on the right there are the following output components:

- **GEN** (GENERAL STATUS) output connector and relevant red lamp - if it is TRUE (relevant lamp on), it indicates that the logic combination, set by the user, of OVC, UNV, OVV and TRIP is TRUE.
- **CH-ON** (CHANNEL ON) output connector and relevant red lamp – if it is TRUE (relevant lamp on), it indicates that at least one channel is ON.

For a detailed description of the mechanical and electrical characteristics of these output connectors please refer to the Technical Specifications in Section 4.3, p.36. A summary of their characteristics is also given in the Reference Table 2.2 and Table 2.3, p.15.

A two-position lever **NIM/TTL Switch** which allows to select either the NIM or the TTL standard for the status/control output signals is placed just underneath the output connector section. If the NIM standard is selected, the relevant green LED will light up. If the TTL standard is selected, the relevant TTL green LED will light up.

Input connectors

The area in the middle contains the INPUT connectors and relevant displays for the control of the channel status.

Starting from left to right, these are:

- **VSEL** (VOLTAGE SELECTION) input connector and relevant green LED – it allows to select one of the two voltage values, V0SET and V1SET, programmed for the relevant channel. If the VSEL input is FALSE, the selected voltage value is V0SET (LED off); if it is TRUE, the selected voltage value is V1SET (LED on).

- **ISEL** (CURRENT SELECTION) input connector and relevant green LED – it allows to select one of the two current limit values, I0SET and I1SET, programmed for the relevant channel. If the ISEL input is FALSE, the selected voltage value is I0SET (LED off); if it is TRUE, the selected voltage value is I1SET (LED on).
- **KILL** input connector and relevant green LED – if it is TRUE (relevant LED on), all the channels will be turned off.

Moreover, on the right there are the following components:

The **RESET push button** allows a manual reset of the channels directly from the front panel. If the button is pressed for more than $T_{RCPU}=100\div 200$ ms (the LED will be red), only the CPU will be reset. If the button is pressed for more than $T_{RCH}= T_{RCPU} + 900$ ms (the LED will become orange), also the boards will be reset and the channels turned off. The **LOC ENABLE / REM ENABLE / DISABLE switch**, a three-position lever switch which allows disabling voltage generation on the channel boards (central position), enabling the channels locally (upper position; LOC ENABLE LED on) or allowing remote enable of the channels (lower position). The remote enable will occur by sending a proper signal on the ENABLE input connector (the REM ENABLE LED is alight as the ENABLE signal is TRUE).

These components and their function is closely related with the adjacent input connectors:

- **RESET** input connector and relevant red/orange LED - it allows to reset the system remotely by sending a proper input signal. If the RESET signal is longer than $T_{RCPU}=100\div 200$ ms (the LED will be red), only the CPU is reset; if it is longer than $T_{RCH}= T_{RCPU} + 900$ ms (the LED will become orange), also the boards are reset and the channels which are ON are turned off.
- **ENABLE** input connector and relevant red LED – if the remote enable mode is selected via the relevant three-position lever switch (see above), it allows to enable the system remotely by sending a proper input signal.

For a detailed description of the mechanical and electrical characteristics of all the input connectors, please refer to the Technical Specifications in Section 4.3, p.36. A summary of their characteristics is also given in the Reference Table 2.2 and Table 2.3, p.15.

N.B.: please note that any type of reset command must be enabled via software in the **RESET FLAG** window by tagging the relevant reset condition with an asterisk (for details see the *User's Manual*).

I/O control

The area at the bottom of the I/O control section contains several I/O connectors and relevant displays for the monitoring of the system status.

Starting from left to right, the I/O connectors are:

- **HVSYNC** (HIGH VOLTAGE SYNCHRONISATION) input/output differential connectors and relevant red LED (**MASTER**) – this is the synchronisation clock (Rs485 standard, 1.25 MHz) for the Primary Power Supply, Power Supply Units and boards. It can works either as MASTER (red LED on), i.e. the synchronisation clock is internally generated and the HVSYNC connector works as output, or as SLAVE, i.e. the synchronisation clock is externally generated and send through the HV SYNC connector which works as input.
- **LOCAL NET** input/output differential connectors and relevant red LED – input/output connectors for the control of non-intelligent systems ONLY.

- **CAENET** input/output connectors and relevant red LED – input/output connectors for CAENET communications.
- **INTERLOCK** input/output connector and relevant red LED – The INTERLOCK connector acts as an open/closed contact. The selection of the contact position (OPEN or CLOSED) which will turn all the channels off is made through the relevant switch. The relevant LED turns on as soon as the INTERLOCK becomes active.
- **TRIP IN/OUT** input/output connectors – it provides four external TRIP lines to handle TRIP conditions.

Moreover, on the right there are the following components:

The **INTERLOCK OPEN/CLOSED switch** allows to select the contact position making active the INTERLOCK function.

For a detailed description of the mechanical and electrical characteristics of these output connectors, please refer to the Technical Specifications in Section 4.3, p.36. A summary of their characteristics is also given in the Reference Table 2.2 and Table 2.3, p.15.

3.7 Rear Panel

The rear part of the system is composed as follows:

The rear part of the SY1527 mainframe is shown in Fig. 3.6, p.35. It can be essentially divided into two main areas:

- the upper 6U-high part where the boards are inserted (refer to Section 3.2, p.20);
- the lower 2U-high part with the actual rear panel in correspondence with the Fan Tray Section (refer to Section 3.3, p.20 for details on the Fan Tray Section).

The actual rear panel, hosted in the lower 2U-high part, features the main switch, the AC-line connector and the knob for the ground connection.

A label, placed in the middle of the panel, shows the system power requirements.

The main switch powers the Power Supply Section and the Fan Tray Unit. This is a thermo-magnetic switch which also acts as a protection for the system.

Power requirements are 100÷230 V a.c., 50÷60 Hz and 3400 W (monophase).

On request, a three-phase version of the system is also available.

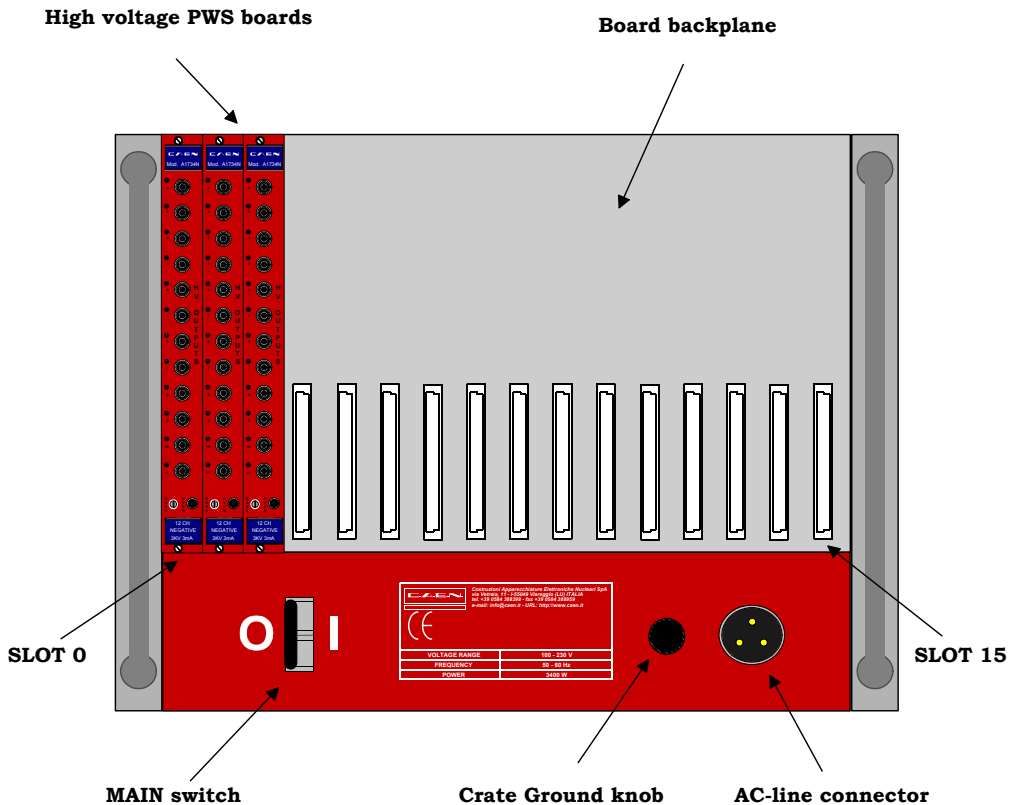

Fig. 3.6 – Rear panel of the SY1527 system

4. Technical specifications

4.1 Packaging

The SY1527 mainframe is hosted in a 19"-wide, 8U-high Euro-mechanics rack. The depth of the mainframe is about 720 mm.

The weight of the mainframe together with one Mod. A1532 and one Mod. A1531 is 24 Kg (boards not included). The Mod. A1532 Power Supply Unit weigh 3.2 kg.

4.2 Power Requirements

Monophase: 100÷230 V a.c. 50÷60 Hz 3400 W

Three-phase (*on request*).

4.3 External connectors, displays and switches

The location of all the components of the front panel is shown in Fig. 3.3, p.24. The function and electro-mechanical specifications of all connectors, displays, switches and buttons are listed in the following subsections. A brief summary of these components' specifications is given in Reference Table 2.2 and Table 2.3, p.15.

4.3.1 INPUTS

All the following inputs are referred to a common ground (COMMON GROUND) and are galvanically insulated up to 150 V with respect to the ground of the crate (CRATE GROUND).

VSEL: *Mechanical specifications:* 00-type LEMO connector.
Electrical specifications: std. NIM level or TTL level; level active.
Function: it allows to select one of the two voltage values, V0SET and V1SET, programmed for the relevant channel. If the VSEL input is FALSE, the selected voltage value is V0SET; if it is TRUE, the selected voltage value is V1SET.

ISEL: *Mechanical specifications:* 00-type LEMO connector.
Electrical specifications: std. NIM level or TTL level; level active.
Function: it allows to select one of the two current limit values, I0SET and I1SET, programmed for the relevant channel. If the ISEL input is FALSE, the selected voltage value is I0SET; if it is TRUE, the selected voltage value is I1SET.

RESET: *Mechanical specifications:* 00-type LEMO connector.
Electrical specifications: std. NIM level or TTL level; level active.

Function: RESET from the front panel. If the RESET signal is $> T_{R_{CPU}} = 100+200$ ms, only the CPU is reset; if it is $> T_{R_{CH}} = T_{R_{CPU}} + 900$ ms, also the boards are reset and the channels which are ON are turned off.

N.B.: please note that any type of reset command must be enabled via software in the RESET FLAG window by tagging the relevant reset condition with an asterisk (for details see the *User's Manual*).

- KILL:** *Mechanical specifications:* 00-type LEMO connector.
Electrical specifications: std. NIM level or TTL level; level active.
Function: KILL from the front panel: it turns all channels off when it is TRUE.
- ENABLE:** *Mechanical specifications:* 00-type LEMO connector.
Electrical specifications: std. NIM level or TTL level; level active.
Function: if the remote enable mode is selected via the relevant three-position lever switch, it is used to enable the system remotely.
- INTERLOCK:** *Mechanical specifications:* 00-type LEMO connector.
Electrical specifications: open/closed contact.
Function: LOCK from the front panel: it acts as a switch that turns all channels off. The selection of the contact position (OPEN or CLOSED) which will turn all the channels off is made through the relevant switch.

4.3.2 OUTPUTS

All the following outputs are referred to the COMMON GROUND and are galvanically insulated up to 150 V with respect to the ground of the crate (CRATE GROUND).

- OVC:** *Mechanical specifications:* 00-type LEMO connector.
Electrical specifications: std. NIM level or TTL level.
Function: at least one channel is in *Over Current*.
- UNV:** *Mechanical specifications:* 00-type LEMO connector.
Electrical specifications: std. NIM level or TTL level.
Function: at least one channel is in *Under Voltage*.
- OVV:** *Mechanical specifications:* 00-type LEMO connector.
Electrical specifications: std. NIM level or TTL level.
Function: at least one channel is in *Over Voltage*.
- CH-ON:** *Mechanical specifications:* 00-type LEMO connector.
Electrical specifications: std. NIM level or TTL level.
Function: at least one channel is ON.
- RST FLAG:** *Mechanical specifications:* 00-type LEMO connector.
Electrical specifications: std. NIM level or TTL level.
Function: a RESET occurred.
- CHK PASSED:** *Mechanical specifications:* 00-type LEMO connector.
Electrical specifications: std. NIM level or TTL level.
Function: the initial check of the system has been successful and that the system is ready.
- TRIP:** *Mechanical specifications:* 00-type LEMO connector.
Electrical specifications: std. NIM level or TTL level.
Function: at least one channel in *Trip* condition.

GEN: *Mechanical specifications:* 00-type LEMO connector.
 Electrical specifications: std. NIM level or TTL level.
 Function: GENERAL STATUS indication; corresponds to the logic combination, defined by the user, of OVC, UNV, OVV, TRIP.

4.3.3 I/O CONNECTORS

4.3.3.1 I/O control section

All the following I/O connectors are referred to the **COMMON GROUND** and are galvanically insulated up to 150 V with respect to the ground of the crate (**CRATE GROUND**).

The following connectors are placed in the **I/O control** area of the front panel:

HV SYNC: *Mechanical specifications:* 2-pin LEMO connectors.
 Electrical specifications: Bidirectional differential signals; RS485 standard, 1.25 MHz.
 Function: this is the synchronisation clock for the Power Supply Units (1.25 MHz). It can work either as MASTER (relevant red LED on), i.e. the synchronisation clock is internally generated and the HVSYNC connector works as output, or as SLAVE, i.e. the synchronisation clock is externally generated and send through the HV SYNC connector which works as input.

LOCAL NET: *Mechanical specifications:* 2-pin LEMO connectors.
 Electrical specifications: Bidirectional differential signals.
 Function: LOCAL bus for the control of 'non-intelligent' systems ONLY. This connector must not be used to connect more 'intelligent' SY1527 crates in daisy-chain.

CAENET: *Mechanical specifications:* 00-type LEMO connectors.
 Electrical specifications: Bidirectional CAENET.
 Function: Usual H.S. CAENET interface.

TRIP IN/OUT: *Mechanical specifications:* Header 5x2 flat connectors (3M, 3793-6202).
 Electrical specifications: Bidirectional differential signals. See Fig. 4.1, p.38 for pin assignment.
 Function: four external TRIP lines to handle TRIP conditions.

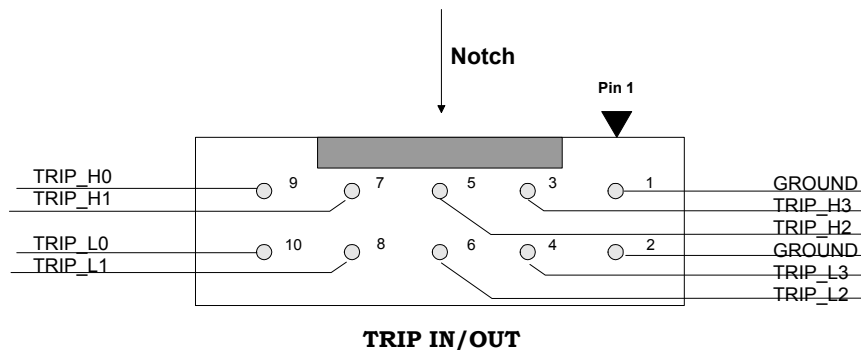

Fig. 4.1 – TRIP IN/OUT pin assignment

4.3.3.2 Interface bus section

The following interface connectors are placed in the **Interface bus** area of the front panel:

RS232 INTERFACE:

Mechanical specifications: 9-pin D-type male RS232 serial port.

Electrical specifications: Refer to Fig. 4.2, p.39 for pin assignment and to Table 4.1, p.40 for the default settings.

Function: it is used to interface a VT100 terminal or an external standard IBM™ Personal Computer for remote control.

MOUSE CONNECTOR:

Mechanical specifications: Mini-DIN 6-pin (PS/2) connector.

Function: connector to attach a standard PC mouse pointer (presently this connection is not working; software to be implemented).

VGA INTERFACE:

Mechanical specifications: 15-pin female VGA port.

Function: it is used to attach a VGA standard monitor.

KEYBOARD CONNECTOR:

Mechanical specifications: Mini-DIN 6-pin connector.

Function: connector to attach a standard PC keyboard.

ETHERNET: *Mechanical specifications:* RJ45 connector.

Electrical specifications: 10/100baseT.

Function: it supplies Intranet/Internet and Telnet access facilities.

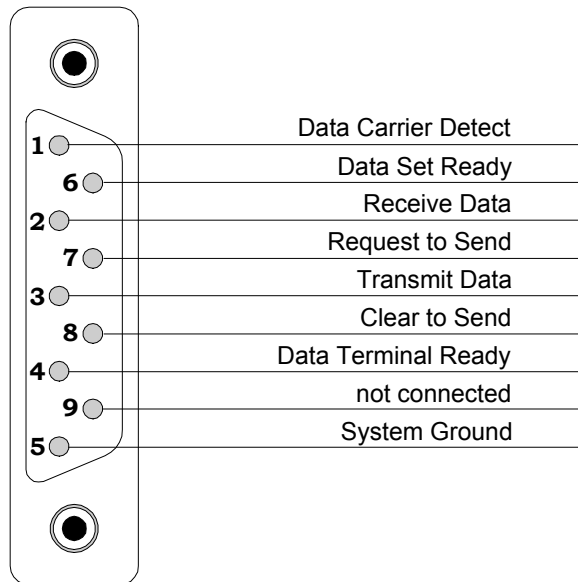

9-pin D-type male RS232 connector

Fig. 4.2 – RS232 pin assignment

Table 4.1 – RS232 Port Default Settings

Baud rate	57600
Parity	None
Character length	8 bits
Number of stop bits	1 bit
Control flow	Xon/Xoff

The following interface boards are **Optional** and the relevant connectors, consequently, may not be present depending on the configuration the user has ordered:

CAN BUS: optional connector.

4.3.4 **DISPLAYS**

- LCD screen:** *Mechanical specifications:* VGA standard, 7.7" colour LCD; 640x480 resolution.
Function: it displays the software menus for the manual control of the system: set-up of channel parameters, interface configurations, etc...
- GEN:** *Mechanical specifications:* red lamp.
Function: it lights up when GENERAL STATUS signal, corresponding to the logic combination of OVC, UNV, OVV, TRIP, is TRUE.
- CH-ON:** *Mechanical specifications:* red lamp.
Function: it lights up when at least one channel is ON.
- OVC:** *Mechanical specifications:* red LED.
Function: it lights up when at least one channel is in *Over Current*.
- UNV:** *Mechanical specifications:* red LED.
Function: it lights up when at least one channel is in *Under Voltage*.
- OVV:** *Mechanical specifications:* red LED.
Function: it lights up when at least one channel is in *Over Voltage*.
- TRIP:** *Mechanical specifications:* red LED.
Function: it lights up when at least one channel is in *Trip*.
- RSTFLAG:** *Mechanical specifications:* red LED.
Function: it lights up after a RESET, according to the user's settings (see the *User's Manual*).
- CHK PASS:** *Mechanical specifications:* green LED.
Function: it lights up when the initial system check has been performed successfully and the system is ready.
- VSEL:** *Mechanical specifications:* green LED.
Function: it lights up when the relevant connector for voltage selection is TRUE.
- ISEL:** *Mechanical specifications:* green LED.
Function: it lights up when the relevant connector for current selection is TRUE.

KILL:	<i>Mechanical specifications:</i> green LED. <i>Function:</i> it lights up when the KILL signal is TRUE.
NIM:	<i>Mechanical specifications:</i> green LED. <i>Function:</i> it lights up when the NIM standard is selected.
TTL:	<i>Mechanical specifications:</i> green LED. <i>Function:</i> it lights up when the TTL standard is selected.
RESET:	<i>Mechanical specifications:</i> red/orange LED. <i>Function:</i> it lights up as a RESET occurs: initially it is red (RESET signal > $T_{R_{CPU}} = 100 \div 200$ ms, the CPU is reset), then it becomes orange (RESET signal > $T_{R_{CH}} = T_{R_{CPU}} + 900$ ms, also the boards are reset and channels turned off).
LOC ENABLE:	<i>Mechanical specifications:</i> red LED. <i>Function:</i> LOCAL ENABLE, it lights up when the <i>Local Enable</i> mode is selected.
REM ENABLE:	<i>Mechanical specifications:</i> red LED. <i>Function:</i> REMOTE ENABLE, it lights up when the <i>Remote Enable</i> mode is selected and the REM EN signal is TRUE.
OVERTEMP:	<i>Mechanical specifications:</i> red LED. <i>Function:</i> OVER TEMPERATURE, it lights up when the relevant condition occurs.
FAN FAILURE:	<i>Mechanical specifications:</i> red LED. <i>Function:</i> FAN FAILURE, it lights up when the relevant condition occurs.
PWR FAILURE:	<i>Mechanical specifications:</i> red LED. <i>Function:</i> POWER FAILURE, it lights up when the relevant condition occurs.
INTERLOCK:	<i>Mechanical specifications:</i> red LED. <i>Function:</i> it lights up when the system is in <i>Interlock</i> condition.
LOCAL NET:	<i>Mechanical specifications:</i> red LED. <i>Function:</i> it lights up when the relevant connector is in activity.
CAENET:	<i>Mechanical specifications:</i> red LED. <i>Function:</i> it lights up when the relevant connector is in activity.
MASTER:	<i>Mechanical specifications:</i> red LED. <i>Function:</i> it lights up when the HV SYNC signal is internally generated.

4.3.5 SWITCHES

NIM/TTL:

Mechanical specifications: two-position lever switch.
Function: selection of the NIM or TTL standard levels for the output signals: OVC, UNV, OVV, CH-ON, RST FLG, CHK PASSED, TRIP and GEN.

- *Left position:* NIM standard level selected;
- *Right position:* TTL standard level selected.

LOC ENABLE/DISABLE/REM ENABLE:

Mechanical specifications: three-position lever switch.

Function: LOCAL ENABLE / DISABLE / REMOTE ENABLE, it allows disabling the voltage generation on the channel boards or enabling it either locally or remotely via a proper input signal:

- *Upper position:* the local enable mode is selected;
- *Central position:* the voltage generation on the channel boards is disabled;
- *Lower position:* the remote enable mode is selected; the channel will be enabled as soon as a proper input signal is sent through the ENABLE connector.

INTERLOCK CLOSED/OPEN:

Mechanical specifications: two-position lever switch.

Function: it is used to select the INTERLOCK operating mode:

- *Upper position:* the INTERLOCK is active when the contact is OPEN;
- *Lower position:* the INTERLOCK is active when the contact is CLOSED.

COMPACT SWITCH:

Mechanical specifications: compact switch pointer with 8 positions + press action.

Function: it allows to move on the LCD screen via its 8 positions and to switch among the options available for the selected field via the press action (the latter corresponds to the SPACEBAR command of a standard keyboard). For details on the function of the compact switch please refer to the *User's Manual*.

4.3.6 **BUTTONS**

KEYPAD:

Mechanical specifications: 15-key keypad with the following keys:

0, 1, ..., 9, ',', '.', CMD, DEL, ACK.

Function: it allows the manual input of numerical data and to select the *Menu Bar* in the software interface. In particular:

CMD key (COMMAND): it allows to select the *Menu Bar* at the top of the screen in the software interface running on the SY1527 system.

DEL key (DELETE): it corresponds to the usual DELETE command of a standard keyboard.

ACK key (ACKNOWLEDGE): it corresponds to the ENTER command of a standard keyboard.

For further details on their functions please refer to the *User's Manual*.

+/- CONTRAST:

Mechanical specifications: push buttons.

Function: it allows to adjust the contrast of the LCD.

+/- BRIGHT:

Mechanical specifications: push buttons.

Function: it allows to adjust the brightness of the LCD.

RESET:

Mechanical specifications: push button.

Function: it allows a manual reset of the channels from the front panel. If the button is pressed for more than $T_{R\text{CPU}} = 100 \div 200$ ms (the

LED will be red), only the CPU will be reset. If the button is pressed for more than $T_{RCH} = T_{RCPU} + 900$ ms (the LED will become orange), also the boards will be reset and the channels which are ON are reset.

N.B.: please note that any type of reset command must be enabled via software in the RESET FLAG window by tagging the relevant reset condition with an asterisk (for details see the *User's Manual*).

4.4 External connectors, displays and switches of the Primary Power Supply

The location of the components on the primary power supply are shown in Fig. 3.3, p.24. The function and electro-mechanical specifications of each component are listed in the following subsections. A brief summary of the components' specifications is also given in Reference Table 2.2 and Table 2.3, p.15.

4.4.1 INPUTS

REMOTE IN: *Mechanical specifications:* 00-type LEMO connector.
Electrical specifications: +12 V, 50 mA max. electrically insulated.
Tolerance: -40% ÷ +20%.
Function: it is used to turn the system ON remotely.

4.4.2 OUTPUTS

REMOTE OUT: *Mechanical specifications:* 00-type LEMO connector.
Electrical specifications: +12 V, 50 mA max., 5–10 sec delay with respect to the power-ON of the system, referred to the crate ground. Tolerance: -20% ÷ +20%.
Function: it is used in daisy-chain configuration to turn on remotely the adjacent daisy-chained crate.

4.4.3 DISPLAYS

MAIN: *Mechanical specifications:* orange LED.
Function: it lights up as the system is connected to the mains and the switch on the rear panel is in position 1.

OK: *Mechanical specifications:* yellow LED.
Function: it lights up when the system is ON, i.e. as soon as:
1) the Turn-On key is in the LOCAL ON position;
or 2) the Turn-On key is in the REMOTE ON position and a proper signal is sent through the REMOTE IN input connector.

+5: *Mechanical specifications:* green LED.

Function: it lights up when the +5 V power supply is present; if it is off it indicates that there is a fault.

- +12:** *Mechanical specifications:* green LED.
Function: it lights up when the +12 V power supply is present; if it is off it indicates that there is a fault.
- 12:** *Mechanical specifications:* green LED.
Function: it lights up when the -12 V power supply is present; if it is off it indicates that there is a fault.

4.4.4 **SWITCHES**

POWER-ON KEY:

Mechanical specifications: three-position turn-on key.

Function: power-ON of the system. It has three different positions:

- the central position corresponds to the system OFF;
- the right position turns the system ON locally;
- the left position enables the system to be turned ON remotely.

4.5 **External displays of the Power Supply Units**

The location of the components on the power supply units are shown in Fig. 3.4, p.26. The function and electro-mechanical specifications of the components are listed in the following subsection.

4.5.1 **DISPLAYS**

- +48:** *Mechanical specifications:* green LED.
Function: it lights up as the +48 V power supply is present; if it is off it indicates that there is a fault.

4.6 **External connectors and switches of the rear panel**

The location of the components on the rear panel are shown in Fig. 3.6, p.35. The function and electro-mechanical specifications of each component are listed in the following subsections. A brief summary of the components' specifications is also given in Reference Table 2.2 and Table 2.3, p.15.

4.6.1 **INPUTS**

CONNECTOR TO THE MAINS:

Mechanical specifications IIT Cannon, CA02COM male connector.

Electrical specifications: see power requirements.

Function: it is used to connect the system to the mains.

4.6.2 SWITCHES

MAIN SWITCH:

Mechanical specifications: magneto-thermal switch.

Function: it is used to power the Power Supply Section of the system. It has two positions:

- **0**, the Power Supply Section is not powered;
- **1**, the Power Supply Section is powered.

5. Unpacking the system

5.1 Check list

Before installing the SY1527 check the list in Table 5.1 containing all the parts you need to install the system.

Table 5.1 – Check list of the parts needed for system installation

(#)	(*)	(**)	Model	Quantity	Description	References
✓	✓	✓	SY152 7	1	Mainframe	See § 3.1, p.18
✓	✓	✓	A1531	1	Primary Power Supply	See § 3.4.2, p.23
✓	✓	✓	A1532	1 ÷ 3	Power Supply Unit	See § 3.4.3, p.25
		✓	-	1	ANSI VT100 terminal	See § 7.3.2, p.55
✓	✓	✓	-	1	Cable to the Mains	See § 4.6.1, p.44
		✓	-	1	RS232 Cable	See § 7.4.2.1, p.57
	✓		-	1	External keyboard (optional)	See § 7.3.1, p.54
	✓		-	1	VGA monitor (optional)	See § 7.3.1, p.54

(#) parts provided with the system

(*) parts needed in standalone configuration

(**) parts needed for remote operation from terminal (using the RS232 interface)

6. Safety information and installation requirements

This section contains the fundamental safety rules for the installation and operation of the SY1527 system.

Read this section thoroughly before starting any procedure of installation or operation of the product.

6.1 General safety information

Review the following safety precautions to avoid injury and prevent damage to this product or any products connected to it. To avoid potential hazards, use the product only as specified.

Only qualified personnel should perform service procedures.

6.1.1 Injury Precautions

Use Proper Power Cord and HV Cables.

To avoid fire hazard, use only the power cord and HV cables specified for this product.

Avoid Electric Overload.

To avoid electric shock or fire hazard, do not apply a voltage to a load that is outside the range specified for that load.

Avoid Electric Shock.

To avoid injury or loss of life, do not connect or disconnect cables while they are connected to a voltage source.

Ground the Product.

This product is grounded through the grounding conductor of the power cord. To avoid electric shock, the grounding conductor must be connected to earth ground. Before making connections to any input or output terminals of the product, ensure that the product is properly grounded.

Do Not Operate Without Covers.

To avoid electric shock or fire hazard, do not operate this product with covers or panels removed.

Do Not Operate in Wet/Damp Conditions.

To avoid electric shock, do not operate this product in wet or damp conditions.

Do Not Operate in an Explosive Atmosphere.

To avoid injury or fire hazard, do not operate this product in an explosive atmosphere.

Do not install the crates on top of each other.

A minimum distance of 15 cm is required between the top of a crate and any other object over it.

6.1.2 Product Damage Precautions

Use Proper Power Source.

Do not operate this product from a power source that applies more than the voltage specified.

Provide Proper Ventilation.

To prevent product overheating, provide proper ventilation.

Do Not Operate With Suspected Failures.

If you suspect there is damage to this product, have it inspected by qualified service personnel.

6.1.3 EC Certifications and Compliances

Use in conformity of the definition with fully equipped mainframe with fully closed slots by boards or dummy panels. Sufficient cooling and mains connection must be secured according to regulations. Signal lines length during all tests was less than 3 m. The RS232 cable must be properly shielded and have a length of less than 3 m. Admitted for powering by industrial mains only.

6.2 Terms in this Manual

These terms may appear in this manual:

WARNING:

Warning statements identify conditions or practices that could result in injury or loss of life.

CAUTION:

Caution statements identify conditions or practices that could result in damage to this product or other property.

6.3 Terms and Symbols on the Product

These terms may appear on the product:

- **DANGER** indicates an injury hazard immediately accessible as you read the marking.
- **WARNING** indicates an injury hazard not immediately accessible as you read the marking.
- **CAUTION** indicates a hazard to property including the product.

The following symbols may appear on the product:



DANGER
High Voltage



ATTENTION
Refer to Manual

6.4 Installation requirements

6.4.1 *Standalone operation*

Before starting the installation procedures, check the following installation requirements:

Operating temperature:	0++40°C (dry atmosphere)
Max. length of cables:	according to cable specifications

Moreover, if you are using an external keyboard or/and an external monitor:

Keyboard:	Standard american PS/2 keyboard
Monitor:	VGA standard monitor

6.4.2 *Remote operation via terminal*

Besides the requirements mentioned above, by using the RS232 interface, remote operation via terminal requires the following:

RS232 cable:	According to § Fig. 7.4 or Fig. 7.5, p.58, depending on the type of terminal RS232 interface.
Terminal:	ANSI VT100 or compatible
Max. length of RS232 cable:	according to cable specifications

7. Hardware installation and set-up

7.1 Installation

Before installing the system, make sure you have read thoroughly the safety rules and installation requirements listed in Section 6, p.47.

For the installation of the SY1527 system in its basic standalone configuration, the following parts are needed (see also the Check List at page 46):

- SY1527 mainframe;
- Primary Power Supply (Model A1531);
- Power Supply Unit (Model A1532), from a minimum of one Unit to a maximum of 3 Units;
- At least one Channel Board;
- Power Supply cable to connect the system to the mains.

7.1.1 *Installing the primary power supply and the power supply units*

Both the Primary Power Supply and the Power Supply Units must be inserted into the Power Supply section located in the front lower 4U-high part of the mainframe (refer to Section 3.3, p.22 for a description of the Power Supply section).

The Power Supply section has four housings equipped with special guides on which the Power Supply Units can slide until they are plugged into the relevant power supply backplane connector.

Any configuration of the SY1527 system includes at least the Primary Power Supply (Model A1531) and one Power Supply Unit (Model A1532).

Usually the system is not delivered to the Customer with the power supplies already inserted into their relevant housings and with the housings left covered with appropriate panels. In order to install the Power Supply Units, please refer to the two following procedures.

To install the Primary Power Supply:

- 1) Turn the system off by the main switch located on the rear panel (refer to Fig. 3.6, p.35), disconnect the system from the mains and wait for at least 1 minute;
- 2) Remove the cover panel, if any, from the rightmost housing by loosening the four single-slot screws following a criss-cross pattern;
- 3) Take the Primary Power Supply (Model A1531) by its handle, sliding it on the guides into the rightmost housing (Housing 0) until it is plugged into the relevant backplane connector;
- 4) Tighten the four single-slot screws on the front panel of the Primary Power Supply following a criss-cross pattern.

To install the Power Supply Units:

- 1) Turn the system off by the main switch located on the rear panel (refer to Fig. 3.6, p.35 for its location), disconnect the system from the mains and wait for at least 1 minute;
- 2) Remove the cover panel, if any, from any of the housings left (Housing from 1 to 3) by loosening the four single-slot screws following a criss-cross pattern;
- 3) Take one Power Supply Unit (Model A1532) by its handle, sliding it on the guides into the housing until it is plugged into the relevant backplane connector;
- 4) Tighten the four single-slot screws on the front panel of the Power Supply Unit following a criss-cross pattern.
- 5) Repeat steps 2), 3) and 4) for each Power Supply Unit to be installed.

CAUTION: please note that the Primary Power Supply must always be placed in the slot on the right (Housing 0), while the Power Supply Units can be placed in any of the three slots left (Housing from 1 to 3, refer to Fig. 3.1, p.19).



CAUTION

THE PRIMARY POWER SUPPLY

MUST BE ALWAYS PLACED IN THE RIGHTMOST SLOT (HOUSING 0)!

To remove any of the installed power supplies from the crate follow this procedure:

- 1) Turn the system off, disconnect the system from the mains and wait for at least 1 minute;
- 2) Verify that the MAIN lamp on the Primary Power Supply is off;
- 3) Loosen the four single-slot screws on the front panel of the power supply following a criss-cross pattern;
- 4) Take the power supply by its handle and unplug it from the backplane connector by sliding it on the guides;
- 5) Screw the cover panel onto the empty housing by tightening the four single-slot screws.
- 6) Repeat steps 3), 4) and 5) for each power supply to be removed.

WARNING: Both the primary power supply and the power supply units can be inserted or extracted from the appropriate housing only if the system is turned off and unplugged from the mains.



WARNING

**DO NOT INSERT OR EXTRACT ANY POWER SUPPLY
BEFORE THE SYSTEM IS TURNED OFF AND UNPLUGGED FROM THE MAINS!**

7.1.2 *Installing the boards*

Both boards and distributors have to be inserted in the Board and Distributor Section located in the rear upper part of the mainframe (refer to Fig. 2.1, p.9).

This section is 6U-high and can house up to 16 vertically positioned boards. Looking into the rear part of the crate, the slots are numbered starting from left (Slot 0) to right (Slot 15). The 16 slots are equivalent, i.e. the user can insert in each slot either a HV/LV board, a distributor or a generic I/O board, indifferently. At Power-On the processor will scan all the slots to find out where the boards are plugged in and what kind of boards they are.

The slots have special guides on which the boards can slide until they are plugged into the relevant connectors of the Board Backplane.

To install the boards (or distributors) follow this procedure:

- 1) Take the board to be installed, sliding it on the guides into one of the 16 slots until it is plugged into the Board Backplane connector;
- 2) Screw the board's front panel of the by tightening the two screws;
- 3) Repeat steps 1) and 2) for each board to be installed.

N.B.: SY1527 system features include live insertion (and extraction) of the boards. It means that it is possible to insert/remove the board into/from the slot without turning the system off. However, before removing the board, **THE USER MUST TURN THE CHANNELS OFF AND DISCONNECT THE HV CABLES AFTER HAVING CHECKED THAT THERE IS NO HIGH VOLTAGE PRESENT.**



WARNING

BEFORE REMOVING THE BOARD, DO THE FOLLOWING:

- 1. TURN OFF THE CHANNELS OF THE BOARD,**
- 2. DISCONNECT THE HV CABLES FROM THE BOARD, AFTER HAVING CHECKED THAT THERE IS NO HIGH VOLTAGE PRESENT,**
- 3. UNSCREW THE BOARD.**

7.1.3 Connecting the system to the mains

A Power Supply cable is provided with the system to connect it to the mains.
To connect the system to the mains, follow this procedure:

1. plug the cable into the relevant connector on the rear panel and tighten the relevant connector screws (see Fig. 3.6, p.35);
 2. insert the plug into the mains (Monophase: 100÷230 V a.c., 50÷60 Hz; 3400 W).
-

7.2 Hardware settings

No hardware setting are required on the SY1527 system.

Conversely, some hardware settings may be required on the boards to be installed in the SY1527 crate and particularly the adjustment of the VMAX HARDWARE via the relevant trimmer. Please refer to the *User's Manual* of the board for details.

7.3 Operating modes and relevant hardware set-ups

The flexibility of the SY1527 system offers a wide range of different hardware set-ups to operate the system. These can be schematically referred to four main categories which emphasise the way of operating the SY1527 system and the type of external devices used to control it. These are:

- **Standalone operation;**
- **Remote operation via terminal** (which includes *Multicrate Operation*);
- **Remote operation by using a Web Browser;**
- **Remote operation via Host computer.**

Each of these operating mode includes more than one possible hardware set-up. In the following subsections these four different operating modes are described in further detail with particular emphasis on the hardware set-ups available for each mode. For further details on the operating modes, please refer to the *User's Manual*.

7.3.1 Standalone operation

Standalone operation is intended as the interactive control and monitoring of one SY1527 system by using the only control devices located on the front panel (LCD screen, keypad and compact switch) or, optionally, an external keyboard and/or VGA monitor which can be connected to the system to make an easier input and monitoring of the data. Fig. 7.1 shows the hardware set-ups available in standalone operation.

Refer to § 7.4.1, p.56 for details about cabling and how to connect the keyboard and/or the monitor. For further details on the operating mode please refer to the *User's Manual*.

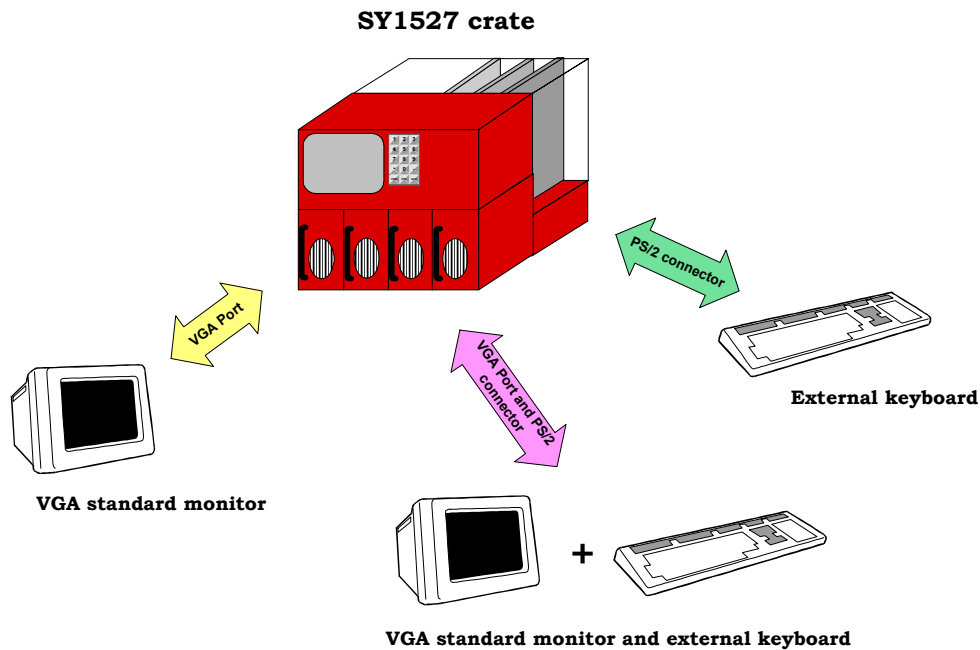

Fig. 7.1 – Standalone Operation

7.3.2 Remote operation via Terminal

Remote Operation via Terminal is intended as the interactive control and monitoring of one or more SY1527 systems by using a remote terminal. The remote operation via terminal can be performed in different ways, according to the interface used to communicate with the system. Nominally, it can be achieved by:

- Using the RS232 interface to connect one SY1527 system to a VT100-like terminal or to a standard PC running a terminal emulator program;
- Using the H.S. CAENET interface to daisy-chain two or more SY1527 systems and then controlling them from a VT100-like terminal via the RS232 interface (*Multicrate Operation*);
- Using the TCP/IP protocol via Ethernet to perform a Telnet connection.

The different hardware configurations which can be arranged for the Remote Operation via Terminal are summarised in Fig. 7.2.

Refer to § 7.4.1, p.56 for details about cabling requirements in the different hardware set-ups. For further details on the operating mode please refer to the *User's Manual*.

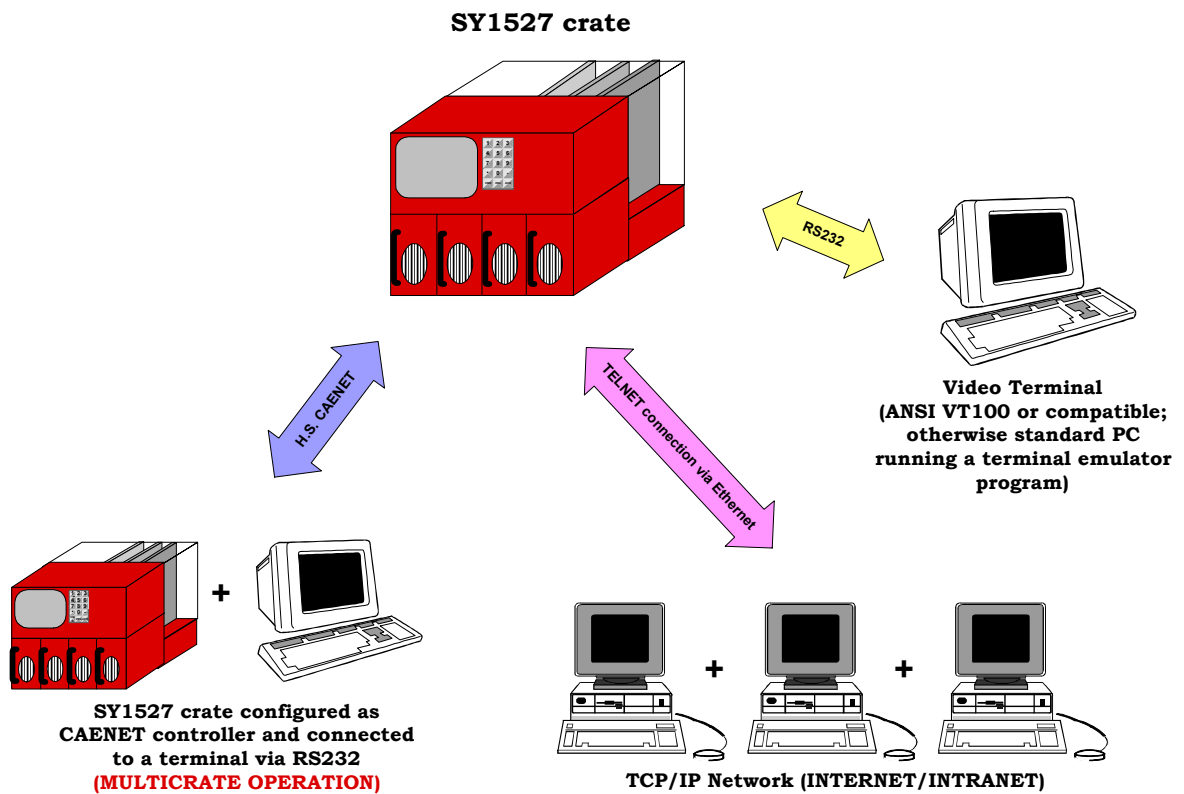

Fig. 7.2 – Remote Operation via Terminal

7.3.3 **Remote Operation via Web Browser**

This feature will be available with the Software Version 2.00 or later.

7.3.4 **Remote operation via Host Computer**

This feature will be available with the Software Version 2.00 or later.

7.4 **Cabling**

The following sections provide instructions for cabling the SY1527 in the various set-ups summarised in § 7.3, p.54.

7.4.1 **Standalone operation**

The definition of standalone operation and the relevant hardware set-ups are given in § 7.3.1, p.54 and sketched in Fig. 7.1, p.54.

Standalone operation without the use of an external keyboard or VGA monitor requires only to connect the system to the mains as described in § 7.1.3, p.53.

NOTICE

**PRESENTLY, AN EXTERNAL KEYBOARD IS MANDATORY TO INPUT THE
ALPHANUMERICAL DATA!**

Standalone operation with an external keyboard and VGA monitor requires, besides the connection of the system to the mains, the following operations:

A) To connect an external keyboard

1. Check that the keyboard is a standard PS/2 keyboard;
2. Identify the PS/2 connector located in the Interface Bus section on the front panel (on the right of the keypad and compact switch);
3. Plug the keyboard into the PS/2 connector (see also Fig. 7.3, p.57);

B) To connect an external VGA monitor

1. Check that the monitor to be connected is a standard VGA monitor;
2. Identify the VGA port (see also Fig. 7.3, p.57) located in the Interface Bus section on the front panel (on the right of the keypad and compact switch);
3. Plug the VGA monitor into the VGA port.

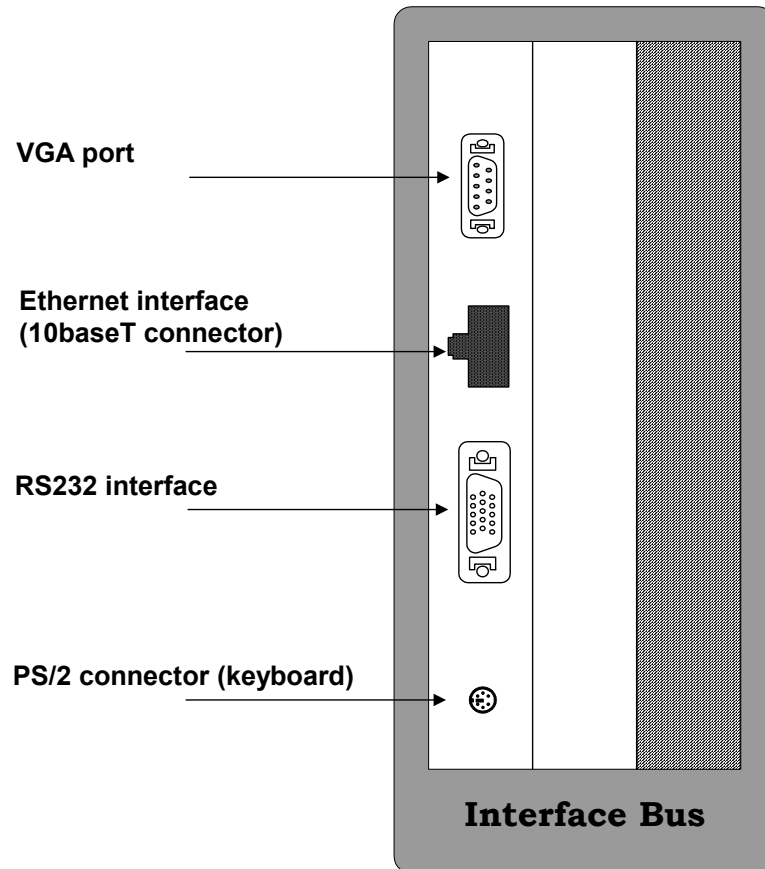

Fig. 7.3 – Location of RS232 interface, VGA port, PS/2 connector and Ethernet interface

7.4.2 Remote operation via terminal

The definition of remote operation via terminal and the relevant hardware set-ups are given in § 7.3.2, p.55 and sketched in Fig. 7.2, p.55. Here below the cabling instructions are given according to the type of connection used to communicate with the system.

7.4.2.1 Using the RS232 interface

The operation of the SY1527 system from an external terminal, either an ANSI VT100 terminal or a standard IBM™ PC running a terminal emulator program, requires the following:

1. Connect the SY1527 crate to the mains as described in § 7.1.3, p.53;
2. If you are using an IBM™ PC running a terminal emulator program verify that the settings are appropriate;
3. Check that the RS232 cable has the characteristics summarised in Fig. 7.4 and Fig. 7.5, according to the type of RS232 connector on the terminal (the example in the figure refers to a DTE device, e.g. a PC);
4. Identify the RS232 interface located in the Interface Bus section on the front panel (see also to Fig. 7.3, p.57);
5. Connect the video terminal (ANSI VT100 or compatible) or the standard PC running a terminal emulator program to the crate by using the RS232 cable.

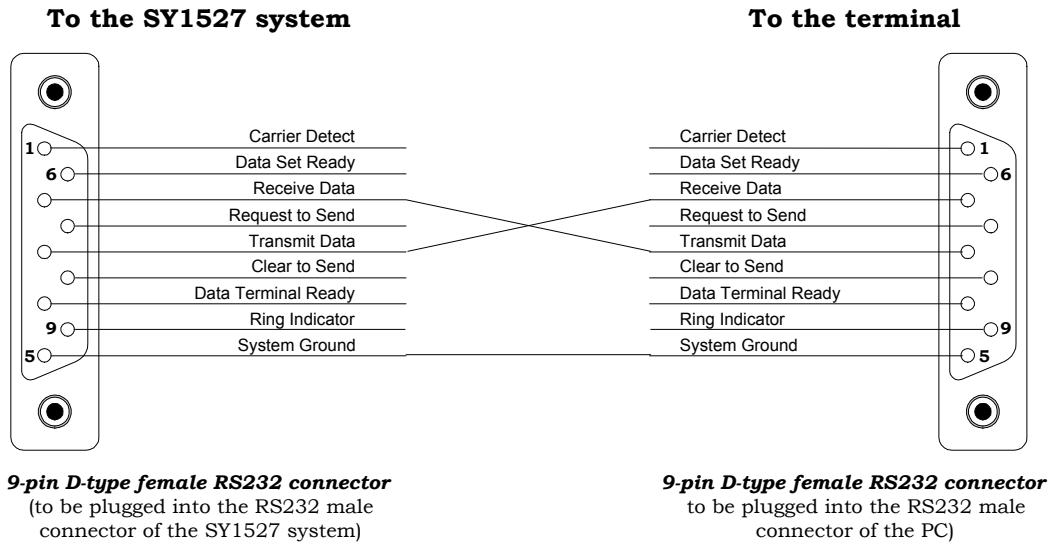

Fig. 7.4 – Electro-mechanical specifications of the RS232 cable (9-pin to 9-pin)

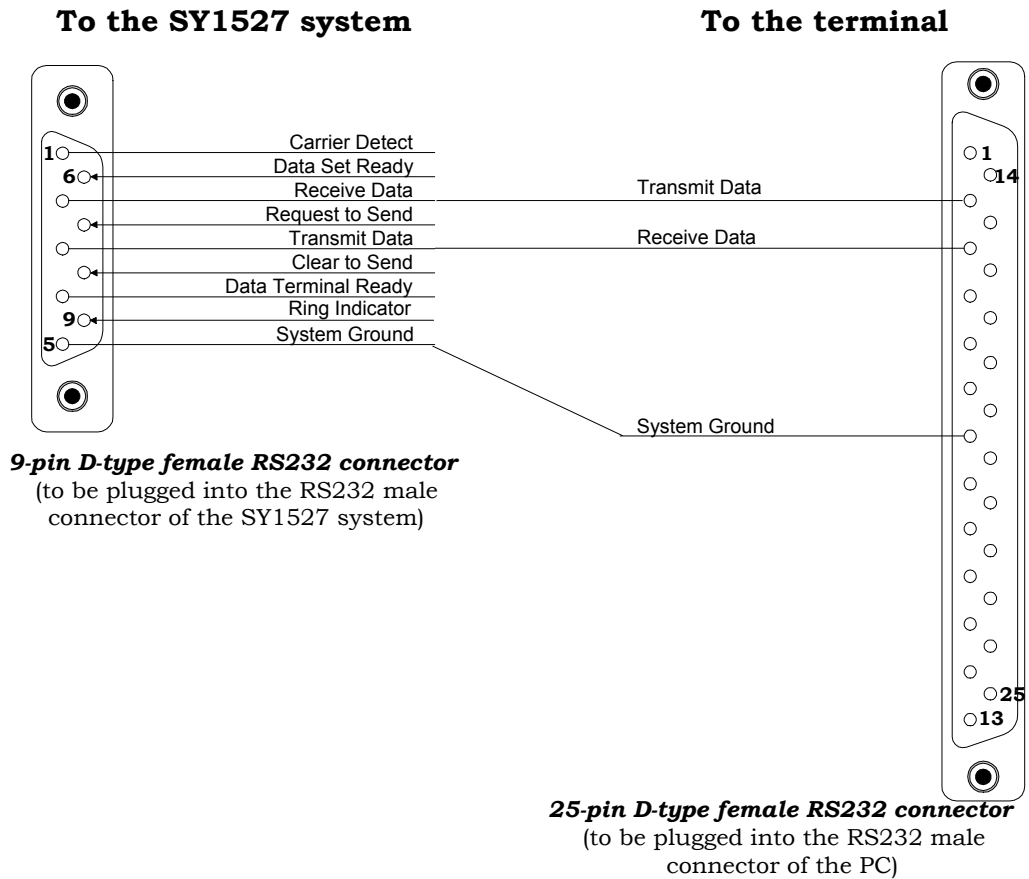

Fig. 7.5 – Electro-mechanical specifications of the RS232 cable (9-pin to 25-pin)

7.4.2.2 Using H.S. CAENET (*Multicrate Operation*)

The operation of the SY1527 system from a terminal not directly connected to the crate can be performed by using H.S. CAENET interface (for details on the H.S. CAENET Network please refer to the *User's Manual*).

This requires at least a second SY1527 system daisy-chained to the first crate and configured as H.S. CAENET controller. The latter crate must be connected to the terminal via the RS232 interface.

Cabling required to work in *Multicrate Operation* is as follows:

1. Daisy-chain two (or more) SY1527 crates by using standard 50 Ω coaxial cables to plug into the relevant H.S. CAENET connectors located on the front panel in the I/O CONTROL area (refer to § 3.6.2, p. 31 and Fig. 3.5, p.30);
2. Terminate the H. S. CAENET line by inserting a 50 Ω impedance terminator in one of the two 00-type LEMO H.S. CAENET connectors in the last and in the first crate of the chain. This operation is done to avoid reflections;
3. Connect the SY1527 system configured as CAENET controller to the terminal by using the RS232 interface as specified in § 7.4.2.1, p.57;
4. Connect the daisy-chained SY1527 crates to the mains as described in § 7.1.3, p.53.

7.4.2.3 Using TCP/IP Protocol (*Telnet connection*)

The Ethernet connector is a standard 10/100baseT connector.

7.4.3 ***Remote operation via Web Browser***

This feature will be available with the Software Version 2.00 or later.

7.4.4 ***Remote operation via host computer***

This feature will be available with the Software Version 2.00 or later.

7.5 **Grounding**

The ground knob (CRATE GROUND) placed on the rear panel can be optionally connected to the ground. The crate ground is already connected to the ground wire of the AC-line power cord.

8. System Power-On

The system's Power-ON can be performed either locally or remotely, as described in the following subsections.

For a full description of the operating modes and software interfaces please refer to the *User's Manual*.

8.1 Preliminary check

Before powering the system, check that:

1. The Primary Power Supply and the Power Supply Units are inserted correctly in their relevant housings and fixed with the relevant screws (refer to § 7.1.1, p.50 for details);
2. The boards, after required hardware settings (see the *User's Manual* of the board), are plugged into the slots and fixed properly (refer to § 7.1.2, p.52 for details);
3. The crate is connected to the mains correctly (refer to § 7.1.3, p.53 for details);
4. Cabling has been performed according to the instructions given in § 7.4, p.56, with reference to the chosen hardware set-up;
5. Safety instructions and installation requirements given in Section 6, p.47 have been thoroughly complied.

8.2 Local Power-On

To power-On the system locally follow this procedure:

1. Turn on the MAIN switch located on the rear panel of the crate (refer to Fig. 3.6, p.35 for its location): the MAIN LED (orange), located on the front panel of the Primary Power Supply (Fig. 3.3, p.24), lights up.
2. Turn the Power-On key, located on the front panel of the Primary Power Supply (refer to Fig. 3.3, p.24), in the right position (ON LOCAL): the OK LED (yellow), located on the front panel of the Primary Power Supply, lights up and the fan tray unit starts to work.

Following these operations, the following LEDs will light up on the front panels of the Primary Power Supply (PPS) and of the Power Supply Units (PSUs) (refer to Fig. 3.3, p.24 and to Fig. 3.4, p.26):

- +5** (green LED on PPS): it indicates the presence of +5 V power supply; if off, it indicates that there is a fault.
- +12** (green LED on PPS): it indicates the presence of +12 V power supply; if off, it indicates that there is a fault.

- 12 (green LED on PPS): it indicates the presence of -12 V power supply; if off, it indicates that there is a fault.
- +48 (green LED on PSU): it indicates the presence of +48 V power supply; if off, it indicates that there is a fault.

After the initial check of the system, the **Welcome Screen** of the User Software Interface will appear on the LCD screen. Please refer to the *User's Manual* for further information on the User Software Interface and the Operating Modes.

8.3 Remote Power-On

To power-On the system remotely follow this procedure:

1. Turn on the MAIN switch located on the rear panel of the crate (refer to Fig. 3.6, p.35): the MAIN LED (orange), located on the front panel of the Primary Power Supply (Fig. 3.3, p.24), lights up.
2. Turn the Power-On key, located on the front panel of the Primary Power Supply (refer to Fig. 3.3, p.24), in the left position (ON REMOTE);
3. Send a proper signal (refer to § 4.4.1, p.43 for specifications) through the REMOTE IN input connector on the front panel of the Primary Power Supply: the OK LED (yellow), located on the front panel of the Primary Power Supply, will light up and the fan tray unit starts to work.

Following these operations, the LEDs listed below will light up on the front panels of the Primary Power Supply (PPS) and of the Power Supply Units (PSUs) (refer to Fig. 3.3, p.24 and to Fig. 3.4, p.26):

- +5 (green LED on PPS): it indicates the presence of +5 V power supply; if off, it indicates that there is a fault.
- +12 (green LED on PPS): it indicates the presence of +12 V power supply; if off, it indicates that there is a fault.
- 12 (green LED on PPS): it indicates the presence of -12 V power supply; if off, it indicates that there is a fault.
- +48 (green LED on PSU): it indicates the presence of +48 V power supply; if off, it indicates that there is a fault.

After the initial check of the system the **Welcome Screen** of the User Software Interface will appear on the LCD screen. Please refer to the *User's Manual* for further information on the User Software Interface and the Operating Modes.

APPENDIX A

SY1527 System Front Panel

